

RECEIVED
GENERAL
FEDERAL BUREAU OF INVESTIGATION
U.S. DEPARTMENT OF JUSTICE
WASHINGTON, D.C. 20535

TARGET PISTOL

T03-35

CERTIFICATE
PIC 8454.049.103.0

1. GENERAL

Pistol TO3-35

No. _____

Before using the pistol carefully study the description and maintenance instructions.

The pistol may differ somewhat from the present description due to the further perfection of its design.

2. PURPOSE

Pistol TO3-35 is designed for sport shooting with target cartridges at stationary targets at a range of 50 *m* in open or indoor shooting galleries.

3. BASIC SPECIFICATIONS

Caliber, <i>mm</i>	5.6
Pistol weight, <i>kg</i>	not more than 1.4
Barrel length, <i>mm</i>	250—300
Number of rifling grooves	6
Length of sighting line, <i>mm</i>	325—375
Shift of mean point of impact, when knob turned through 1 click, the barrel length being 300 <i>mm</i> :	
in elevation, <i>cm</i>	1
in windage, <i>cm</i>	1
Trigger pull, adjustable, <i>g</i>	from 10 to 75

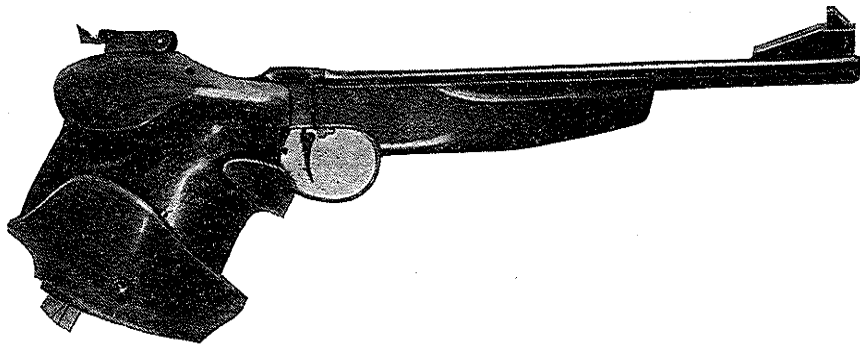

Fig. 1. Target Pistol TO3-35

4. PARTS OF PISTOL AND DELIVERY LIST

4.1. Parts of pistol

(See Appendix No. 1)

4.2. Delivery list

Nos	Description	Q-ty	Designation
1	Firing pin	1	01103.000.021
2	Mainspring	2	01103.000.022
3	Sear spring	1	01103.000.024
4	Spring	1	01103.002.007
5	Front sight 4.5 <i>mm</i>	1	01103.001.006
6	Front sight 3.5 <i>mm</i>	1	01103.001.007
7	Front sight 5.0 <i>mm</i>	1	01103.001.008
8	Front sight 5.5 <i>mm</i>	1	01103.001.009
9	Rear sight 3.0 <i>mm</i>	1	01103.000.038
10	Rear sight 2.8 <i>mm</i>	1	01103.000.039
11	Rear sight 3.1 <i>mm</i>	1	01103.000.041
12	Rear sight 3.4 <i>mm</i>	1	01103.000.042
13	Screw-driver 5—7.5 <i>mm</i>	1	01103.003.020
14	Screw-driver 2.5 <i>mm</i>	1	01125.006.004
15	Drift pin dia. 1.25 <i>mm</i>	1	01125.006.001
16	Drift pin dia. 2.25 <i>mm</i>	1	01125.006.003
17	Cleaning rod	1	01103.003.010
18	Bristle brush	5	01125.006.160
19	Oiler	1	
20	Scourer	1	01103.003.001
21	Pistol case	1	01103.003.040
22	Cover	1	01103.096.000

5. PISTOL DESIGN AND PRINCIPLE OF OPERATION

The main characteristics of the pistol are as follows:

the barrel bore is locked by means of the bolt rocking on its pin;
the barrel is attached to the receiver by a guiding cylinder and thread;
a walnut pistol grip is specially shaped and has an adjustable palm rest;
the sight enables fine adjustment of the rear sight in windage and elevation;

the front and rear sights are replaceable;

the firing mechanism housed in the bolt is actuated by the accelerator mounted on a separate base plate:

the accelerator is armed by pressing all the way downward the cocking lever fitted on the pistol left side;

the trigger may be shifted along the pistol and turned round its vertical axle;

the trigger pull and creep are adjustable;
cartridges are fed into the chamber manually;
the cartridge is locked in the chamber by the bolt when the bolt lever is engaged by the latch in the extreme rearward position;
the bolt is opened and the firing pin is cocked by shifting the bolt lever into the frontmost position;
a fired cartridge case is removed by the extractor on opening the bolt.

6. SAFETY RULES

CAUTION! Never point the pistol at people. Keep the piston unloaded, with the accelerator unarmed and firing pin released.

When the pistol is loaded, it may be pointed only at a target.
If the accelerator is armed, avoid sharp jerks and knocks of the pistol.

7. PARTIAL DISASSEMBLY AND ASSEMBLY OF PISTOL

Before disassembling the pistol be sure to unload it or check to see that it is unloaded.

To disassemble the pistol use the following procedure:

Remove the palm rest by unscrewing its fastening screw.
Remove the right cheek fastening screws and detach the cheek.
Remove the left cheek in the same manner.
Unscrew the nut from the grip base slot.
Detach the bolt by knocking out its pin with a drift pin.

Shift the bolt lever forward. Pressing with the forefinger upon the front part of the bolt, move the bolt lever to the rearward position. Grasp the bolt by the raised rear part and withdraw it from the receiver.

To inspect and clean the accelerator remove the forearm fastening screw. Withdraw the forearm with the accelerator from the barrel in the direction of the grip. Detach the forearm from the accelerator.

Assemble the pistol using the following sequence:

Install the forearm, connect the accelerator with the forearm by securing them to the stop by the screw.

Retract the bolt lever to the extreme rearward position and engage it by the latch. Insert the bolt into the receiver tipping its front part downward. Press the rear part of the bolt, and push the bolt lever forward until the bolt cylindrical portion is set in the respective surface of the receiver. Close the bolt by the bolt lever and insert the pin.

Install the right cheek and fix it by the screws.
Install the nut in the grip base slot.
Mount the palm rest on the right cheek and secure it by turning the screw into the nut.

Install the left cheek and secure it with screws.

To adjust the palm rest loosen the screw fastening the base to the nut and shift the palm rest along the right cheek.

Complete disassembly and assembly of the pistol can be performed only by expert armourers.

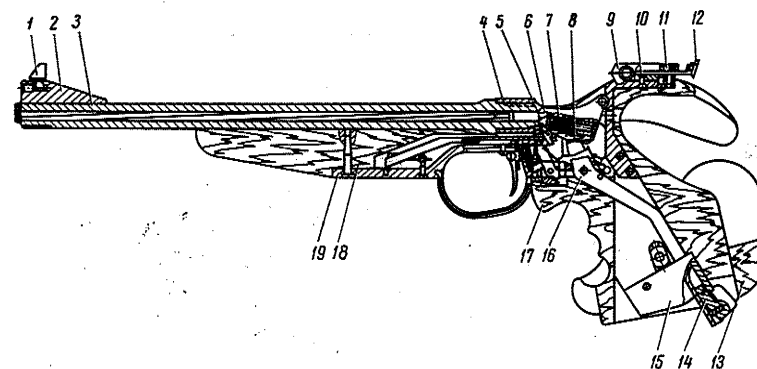

Fig. 2. Pistol: General View (Cross section):

1—front sight; 2—front sight base; 3—barrel; 4—receiver; 5—sear lever; 6—bolt; 7—firing pin; 8—sear; 9—sight body; 10—sight leaf; 11—elevation knob; 12—rear sight; 13—palm rest; 14—bolt lever latch; 15—grip base; 16—bolt lever; 17—grip; 18—forearm; 19—accelerator box

8. HANDLING AND MAINTENANCE

The length of service life and faultless operation of the pistol mechanisms largely depend on careful and skilful handling.

Careless and inexpert handling, frequent complete disassembly and assembly of the weapon reduce the service life of the pistol.

To prepare the pistol for firing proceed as follows:

remove lubricant from the barrel and outer surfaces of the pistol;
inspect the pistol (barrel, sights, bolt);

check the trigger pull, creep and the operation of the trigger mechanism.

Adjust the trigger pull and creep by turning adjusting screws 18 and 24 (Fig. 3).

The shooter should observe the following rules:

1. Be sure that the pistol parts and mechanisms are clean and in sound condition.

2. Inspect, clean and lubricate the pistol immediately after firing and then at least twice a month.

3. Never clean the barrel from the muzzle end.

The following materials are recommended for cleaning and oiling the pistol:

(a) alkaline solution — to remove powder deposit;

(b) rifle oil — to lubricate parts after cleaning;

(c) clean cotton or flax waste or gauze — to clean, wipe and lubricate parts;

(d) tow cleaned from shive — to clean the barrel bore only.

Cleaning should be continued until all traces of powder deposit are removed from the barrel bore and chamber.

After cleaning the surface of the barrel bore and chamber they should be instantly wiped dry and coated with a uniform thin layer of rifle oil by means of a bristle brush.

Clean the barrel bore through a hole in the grip without disassembling the pistol.
Wipe the wooden parts of the grip and forearm with dry rags.

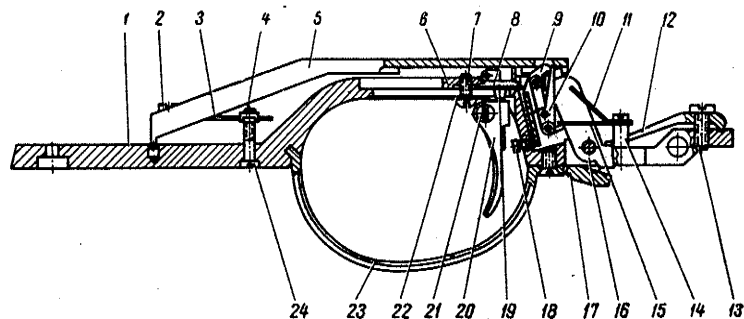

Fig. 3. Accelerator:

1 — accelerator box; 2 — screw; 3 — big lever spring; 4 — nut; 5 — big lever; 6 — slide; 7 — slide screw; 8 — turning sleeve; 9 — small lever; 10 — middle lever; 11 — limiter; 12 — accelerator spring; 13 — screw; 14 — bushing; 15 — middle lever spring; 16 — accelerator striker; 17 — cocking lever; 18 — creep adjusting screw; 19 — trigger pin; 20 — trigger; 21 — trigger adjusting screw; 22 — washer; 23 — trigger guard; 24 — trigger pull adjusting screw

9. ACCEPTANCE CERTIFICATE

During the firing test the pistol was checked for proper functioning of its parts and fire accuracy by shooting at a range of 50 m from a special mount with target ammunition, lot No. H-66

The results of the firing test are shown in the Table below:

No. of groups of ten shots	Dispersion diameter, mm
1	23
2	16
3	27
4	20
5	28
	Average <u>22,8</u>

The fire accuracy of the pistol is considered satisfactory, if each of the five registered groups of shots does not produce the dispersion diameter greater than 25 mm.

The meaning of stamps and markings on the pistol is explained in Appendix No. 2.

Pistol TO3-35 _____ No. _____ has been found fit for service.

Assembly Shop Manager

Quality Inspector



Appendix No. 1

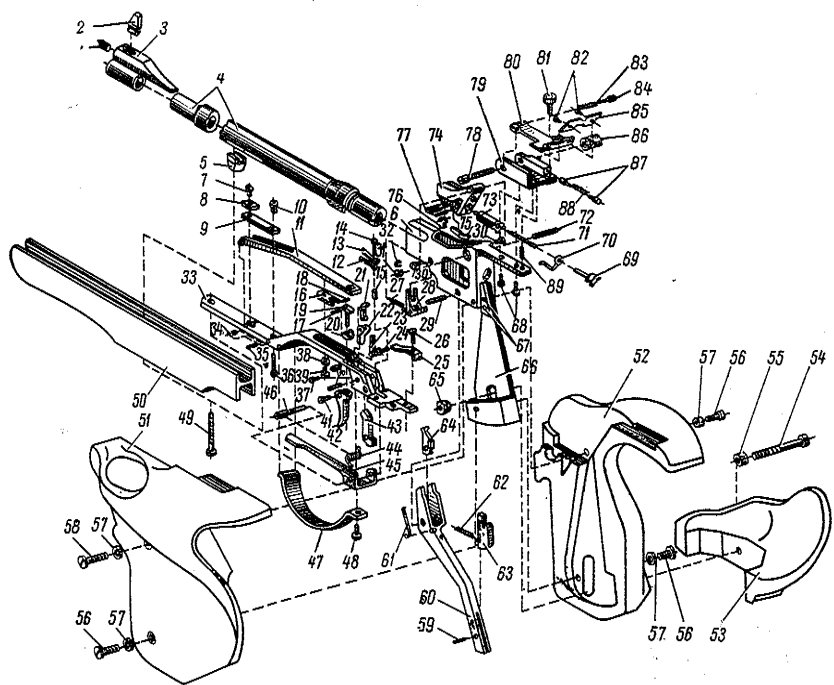

Appendix No.1

Nos	Description	Designation
1	Front sight screw	01103.001.011
2	Front sight	01103.001.005
3	Front sight base	01103.001.015
4	Barrel	01103.001.012
5	Stop	01103.001.004
6	Receiver	01103.001.013
7	Screw M3×5 GOST 1491—62	
8	Washer	01103.002.028

Continued



Nos	Description	Designation
9	Spring	01103.002.027
10	Nut	01103.002.002
11	Big lever	01103.002.026
12	Spring	01103.002.007
13	Limiter	01103.002.008
14	Screw M2 × 10 GOST 1491—62	
15	Bushing	01103.002.009
16	Slide	01103.002.003
17	Trigger pin axle	01103.002.033
18	Trigger pin spring	01103.002.032
19	Trigger pin	01103.002.029
20	Turning sleeve	01103.002.031
21	Small lever	01103.002.004
22	Bearing lever	01103.002.005
23	Middle lever	01103.002.034
24	Small pin	01103.002.035
25	Accelerator spring	01103.002.015
26	Screw M3 × 8 GOST 1491—62	
27	Extractor spring	01103.001.003
28	Extractor	01103.001.001
29	Lever pin	01103.000.001
30	Extractor pin	01103.001.002
31	Bolt pin bushing	01103.000.002
32	Locking spring	01103.000.003
33	Accelerator box	01103.002.001
34	Block	01103.002.024
35	Screw	01103.002.025
36	Adjusting screw	01103.002.022
37	Adjusting screw	01103.002.017
38	Washer	01103.002.012
39	Slide screw	01103.002.023
40	Pin	01103.002.019
41	Screw M2 × 7 GOST 1475—62	
42	Trigger	01103.002.018
43	Accelerator striker	01103.002.006
44	Cocking lever spring	01103.002.016
45	Cocking lever	01103.002.014
46	Cocking lever pin	01103.002.021
47	Trigger guard	01103.002.013
48	Trigger guard screw	01103.002.011
49	Screw	01103.000.015
50	Forearm	01103.000.009
51	Left cheek	01103.000.012
52	Right cheek	01103.000.011
53	Palm rest	01103.000.013
54	Palm rest screw	01103.000.007
55	Washer 5 HO 5600—68	
56	Grip screw	01103.000.005
57	Washer 3 HO 5600—68	
58	Grip screw, long	01103.000.006
59	Latch pin	01103.000.048
60	Bolt lever	01103.000.045

Continued

Nos	Description	Designation
61	Spring	01103.000.016
62	Latch spring	01103.000.047
63	Latch	01103.000.046
64	Supporting plate	01103.000.017
65	Palm rest screw nut	01103.000.008
66	Grip base	01103.001.014
67	Rivet 3×12 GOST 10300—62	
68	Sight screw	01103.000.014
69	Mainspring stop	01103.000.023
70	Sear spring	01103.000.024
71	Mainspring	01103.000.022
72	Bolt pin	01103.000.004
73	Firing pin	01103.000.021
74	Bolt	01103.000.019
75	Sear	01103.000.025
76	Sear lever	01103.000.026
77	Pin	01103.000.027
78	Sight pin	01103.000.031
79	Sight body	01103.000.028
80	Sight leaf	01103.000.029
81	Elevation knob	01103.000.034
82	Rear sight screw	01103.000.043
83	Sight leaf spring	01103.000.044
84	Guiding rod	01103.000.032
85	Rear sight	01103.000.037
86	Windage knob	01103.000.033
87	Tip	01103.000.035
88	Tip spring	01103.000.036
89	Sight leaf spring	01103.000.049

STAMPS AND MARKINGS

Appendix No. 2

Mark	Meaning	Location
	Manufacturer's trade mark	On receiver upper edge
TO3-35	Pistol model	On receiver upper edge
№ 000	Pistol No.	On right side of receiver edge
	Pistol accepted by Quality Inspector	On forearm end face
	Pistol model tested at State Test Station	On left side of receiver