

SHOTSHELL RELOADING WITH THE

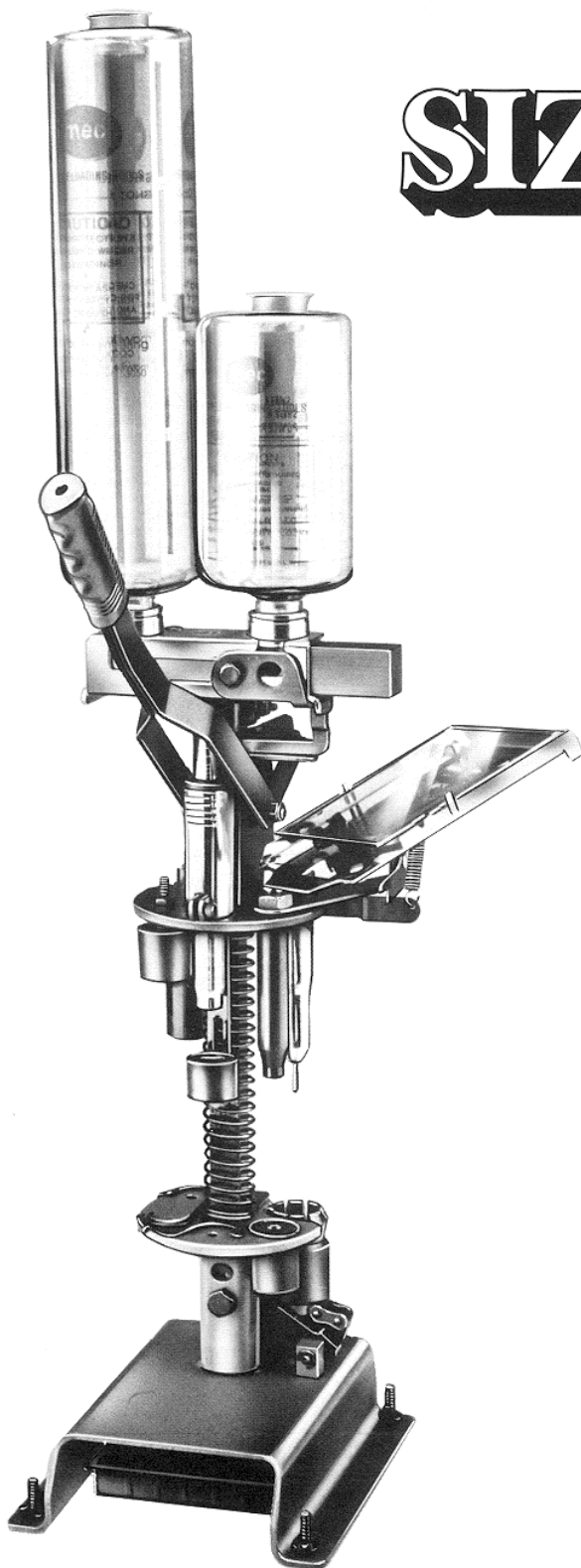

SIZEMASTER



Mayville Engineering Company is the world's largest manufacturer of quality shotshell reloaders and that's why everyone looks to MEC for leadership. And that's why MEC guards its reputation for quality and precision. This quality and precision is built into every one of MEC's "New Generation" reloaders providing you with the most up-to-date engineering, most sophisticated, trouble-free shotshell reloader available.

Your MEC SIZEMASTER is no exception. It offers simplicity without sacrificing convenience and efficiency. And it's loaded with premium features. The resizing station accommodates both high or low brass heads, and the highly accurate "Power-Ring" collet resizer returns every base to factory specifications. An eight-fingered collet squeezes the base back to original dimensions, then opens up quickly to release the shell.

The E-Z Prime auto primer feed lets you load it and forget it. The E-Z Prime dispenses primers automatically eliminating the time consuming bother of handling individual primers. It holds a full box of primers and greatly enhances the speed of production.* Your MEC SIZEMASTER also features the Pro-Check which remembers the loading sequence and prevents spilled powder or shot.

Several other features contribute to the MEC SIZEMASTER versatility. There is a large size shot bottle and a new one piece Spindex crimp starter with swivel action to correctly align with the original shell creases and can be changed from 6-8 pt. in seconds. Best of all, the crimp die is now manufactured from a revolutionary new material called "Dupont Zytel" which makes maintenance a breeze. It is absolutely rustproof and actively resists the build-up of residue carried into the die on fired shells. Thus, the die slides easily over the casing, making a perfect crimp every time.

We know you'll be glad you bought a MEC SIZEMASTER. We've combined revolutionary new features for unequalled performance — with rugged simplicity for years of dependable service. A single-stage reloader that offers this much precision, convenience and efficiency, can only be the MEC SIZEMASTER.

This reloader will load steel shot shells. To convert to steel shot, kit #8433 is necessary. Do not use components designed for use with lead shot when loading steel shot shells.

A special steel shot charge bar must be used when loading steel shot. Do not use charge bars designed for lead shot when loading steel shot shells.

**E-Z Prime not offered on .410 gauge model.*

LET'S LOOK INSIDE A SHOTSHELL...

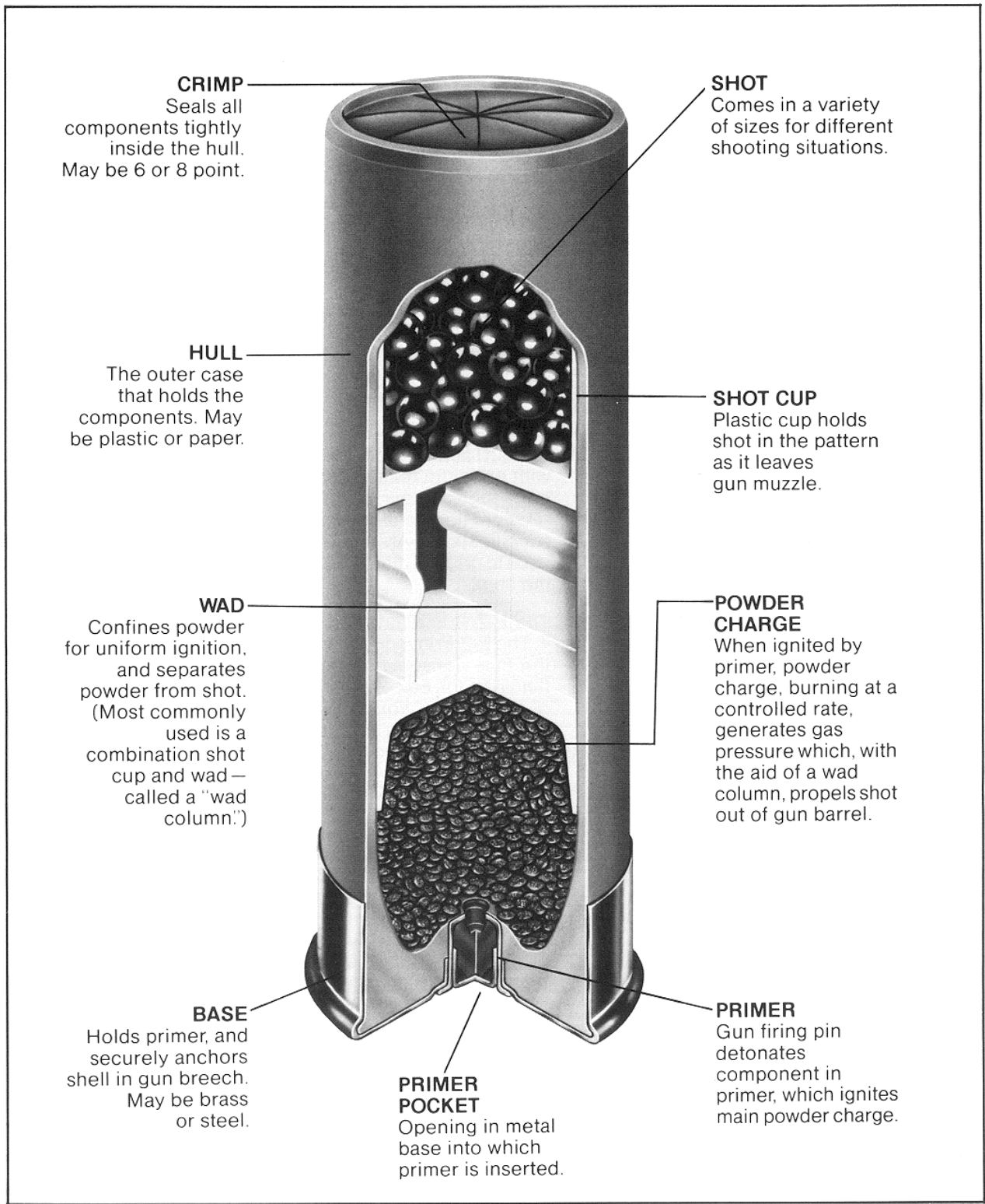

Photo No. 1

HOW TO SELECT COMPONENTS

As we saw on the previous page, a shotshell is made up of several different components. There are many different variations of each component.

Packed with every MEC reloader are brochures supplied by leading component manufacturers. A study of this literature will show you numerous combinations of primer, powder charge, wad and shot you should use with each empty hull, for waterfowl, small game, or trap and skeet. Each combination of components has been carefully tested by ballistics experts for maximum effectiveness and safety. ***Experimenting with combinations not recommended by a component manufacturer is foolhardy and dangerous!***

Choosing the Hull.

Proper choice of empty hulls is one of the most important choices you must make to keep your reloading simple.

The problems encountered by trying to use any and all of the hulls you may find are usually quite discouraging. Not all hulls have the same capacity. Not all hulls have the same crimp. Each time that you use a hull with a different capacity (usually caused by different base wad height) you must assemble a different set of components to properly fill this case.

We are not recommending that you throw away all the nonstandard hulls that you have but are advising you to keep it simple until you have gained the experience necessary to assemble the different components.

Selecting the Right Wad.

The wad is that part of the shotshell between the powder and the shot. A tight seal permits the expanding gas from the burning powder to push the shot column out of the gun barrel with maximum velocity.

Modern "wad columns" combine both the shot cup and the wad in one piece. These one-piece wad columns are the easiest to use, and therefore are most popular—especially with beginning reloaders. There are many different kinds. Use only the specific wad column recommended for the other components you are using.

The Shot.

There are two kinds of shot—lead and steel. **Lead and steel shot are not interchangeable.** Reloading with steel shot requires special wads. Using wads designed for lead shot will not only ruin your gun, but could cause high pressures that could burst the gun causing injury or death to the shooter or bystander.

When loading with steel shot, it is imperative that steel shot components be used and the instructions for these components be followed to the letter. MEC does not design, manufacture or approve any reloading component. It is the responsibility of the individual to select components that they feel are suited for steel shot reloading.

As the size of the shot increases, fewer pellets can be loaded into the hull. The smaller sizes are used for trap and skeet, doves, varmints, small game, etc. The larger shot sizes are for heavier game—ducks, geese, turkeys, etc.

SHOT SIZES

(Shown Actual Size)

Lead Shot		Buckshot	
No.	Dia.		
9	● .08"	4	● .24"
8½	● .085"	3	● .25"
8	● .09"	1	● .30"
7½	● .095"	0	● .32"
7	● .10"	00	● .33"
6	● .11"		
5	● .12"		
4	● .13"		
2	● .15"		
Air			
Rifle	● .175"		
BB	● .18"		

All Powder Is Not Alike.

Different powders have different burning speeds, which make them useful for different jobs. The heavier the shot load, the slower the powder must burn. It takes longer to accelerate a heavy shot load than it does a light one.

A fast-burning powder ignited behind a heavy shot load could cause excessive "breech pressure" which might cause damage to the gun and even injury to the shooter or bystander. (Breech pressure is the pressure of the gas which is created by the burning powder. It is this breech pressure which forces the shot through the barrel.)

On the other hand, using a slow-burning powder to propel a light load of shot will not work effectively. Without the proper pressure buildup, many powders will not burn uniformly and impart sufficient velocity to the shot. *Never interchange powders for reloading steel shot.* A powder that generates acceptable pressures on 1½ oz. of lead shot cannot be used to propel 1½ oz. of steel shot. The pressures will raise to dangerous levels.

Which Primer to Use?

The primer ignites the powder. When you pull the trigger, the hammer falls on the firing pin, denting the primer cup. This causes the component in the primer to detonate, igniting the main powder charge.

Different primers have different characteristics depending on their purpose. Use only the primer that is recommended by the component manufacturer for the hull, powder, wad, and shot load you are using.

A WORD ABOUT SAFETY

To make reloading safe, all it takes is common sense and the ability to read and follow the directions of the various component manufacturers.

When you purchase your powder, get a copy of the "SAAMI" (Sporting Arms and Manufacturers Institute) pamphlet on the properties and storage of smokeless powder. Read this literature and abide by it. Generally speaking, powder is safer than gasoline, because unlike gasoline, it does not give off explosive fumes. If ingited, powder will burn until it consumes itself. Modern smokeless powders must be confined to cause an explosion. The containers that powder is purchased in are designed to burst without causing an explosion if the powder is accidentally ignited. Your powder should be kept in these containers until it is used up. It is unsafe to put powder in a glass jar or bottle or any other container which could cause pressure buildup. Store your powder where there is no chance of sparks, fire or flame, where it is cool and dry, and where children cannot reach it.

Primers also require care in handling. Never take primers from the container that they come in until ready for use. Storage of primers in anything but

the container that they were purchased in is unsafe. Exposing a primer to excessive heat, or to fire, flame or rough handling will cause it to explode. Do not store primers near your powder or where children can get at them.

When a manufacturer tells you to use a particular set of components in a shell it means precisely that. You cannot indiscriminately experiment with or substitute components without experiencing problems. At best, you will get a shell which fails to give the performance you expect. At worst, you may inflict serious injury upon yourself or someone else who fires your reloaded shells. The manufacturer has extensively tested recommended loads and knows how they perform. Always follow these recommendations exactly.

It is also highly recommended that safety glasses be worn when reloading.

When finished reloading, remove the containers from your machine and seal them with caps and put them in a safe place. Also return all primers to their original container and store them in a safe place. It is important that these materials are kept out of the reach of children and other unauthorized persons.

SHOTSHELL RELOADING WITH THE SIZEMASTER

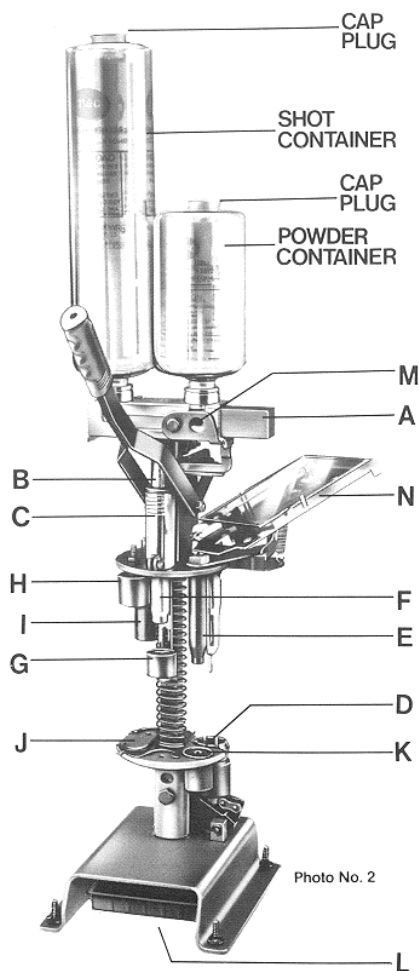

After removing your new reloader from its carton, inspect it carefully for damage. In addition to the reloader itself, you should have these additional parts shown in photo #3.

Before you actually try reloading, we recommend that you look over your loader and compare it with this diagram identifying all the parts and dies you'll be using.

- A. The CHARGING BAR is located just under the powder and shot containers. Moving the bar to the left charges the powder. Moving the bar to the right charges the shot. Make sure shot and powder containers are placed correctly.
- B. WAD HEIGHT INDICATOR used to disclose improper wadding.
- C. WAD PRESSURE INDICATOR gives the exact amount of pressure actually being applied to wad column at bottom of handle stroke.
- D. RESIZE CHAMBER — The spent primer is ejected and the shell mouth is expanded. The Power Ring collet resize chamber squeezes the metal base back to original dimensions with one stroke of the handle.
- E. REPRIMING PUNCH — seats new primer into shell from PRIMER SEATING ASSEMBLY (K).
- F. RAMMER TUBE — through which powder and shot are dropped into the shell. This tube is used also to seat the wad column.
- G. ADJUSTA-GUIDE WAD FEED — permits quick and accurate seating of wad column.
- H. CRIMP STARTER — 8-point, 6-point, (smooth cone optional for paper shells).
- I. CRIMPING STATION — containing the exclusive cam-operated two-stage crimping apparatus. Die is completely adjustable for depth of crimp.
- J. SHELL HOLDER — holds shell down on handle upstroke.
- K. PRIMER SEATING ASSEMBLY
- L. PRIMER CATCHER — slips under the base.
- M. PRO-CHECK — automatically programs the charge bar and prevents spilling of powder and shot.
- N. PRIMER FEED ASSEMBLY

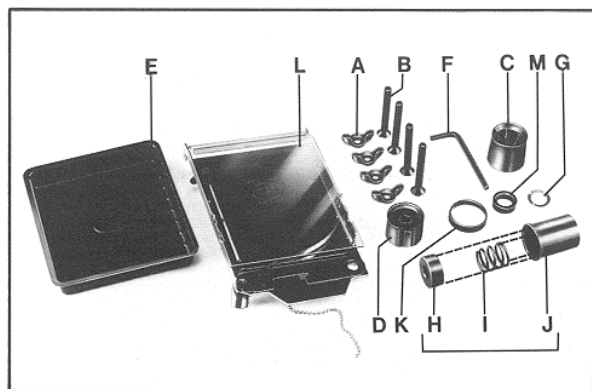

Photo No. 3

Contents of Parts Bag

- | | |
|----------------------------------|---|
| A. Wing Nuts (4) | G. Brass Washer |
| B. 1/4 20 Countersunk Screws (4) | H. Primer Pad |
| C. Star Crimp* | I. Primer Seating Spring |
| D. Extra Wad Guide | J. Primer Cup |
| E. Primer Catcher | K. Ring Spacer (8111) (3" 12 & 20 ga. only) |
| F. Hex Wrench | L. Primer Feed Assembly |
| | M. Deprime Spacer (8126) (3" only) |

(H, I, J.) Assemble as shown (G) Brass washer is used on fine grained powders (Winchester) to prevent leaking. Install on the powder side of the measure by removing the grommet Photo # 9 . Place the smooth side of this washer on the charge bar and replace grommet.

**12, 16, 20 gauge only.*

MOUNTING YOUR RELOADER

Although it is desirable to have your reloader mounted permanently to a bench, it is not a necessity. If you cannot mount your reloader permanently to a bench, we recommend placing your reloader on a piece of 3/4 x 12 x 18" plywood. Photo #4 shows the ideal location for your loader on a piece of plywood. Install your reloader by placing it in the proper location, marking through the holes with a pencil, then remove your reloader and drill a 9/32 hole at these locations. Put the reloader back in position and fasten securely with the 1/4 x 20 x 2" counter sunk stove bolts with wing nuts. Place the bolts in from the bottom up and draw them up tight enough so the heads are slightly depressed so that they will not scratch the bench or table.

By this time you should have made your choice of components. Photo #5 shows how these components should be placed for the most efficient operation of your Sizemaster

Remove the primer feed tray from the parts carton.

Remove the wing nut from the stud on the bottom of the tray.

Now place the base of the primer tray over the deprime punch and the stud through the hole in the primer feed support bracket. Now replace the wing nut to fasten the tray to the bracket.

Now bring the handle of the machine to the bottom of its stroke and open the cover of the primer feed. Place some primers on the tray and close the cover. The cover must snap firmly closed. Now hook the chain in Photo #6 leaving four links to the right of the lever.

Place a finished shell in the final crimp station and operate the handle. As long as the shell is in the final crimp station, the feed should drop a primer with each handle stroke. When the shell is removed, the feed should not operate. If the feed does not operate, try shortening or lengthening the chain until it does operate properly.

Loading the automatic primer feed.

Lower handle and open primer feed cover. Place box of primers on tray Photo #7. Slide box cover off slowly, leaving liner and primers on tray Photo #8. Carefully lift the liner, leaving the primer on the tray Photo #8. Close primer tray cover.

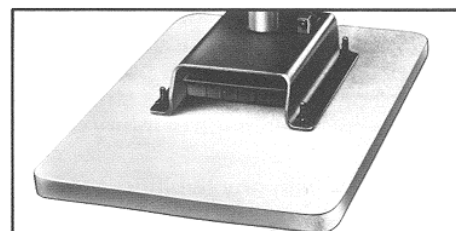

Photo No. 4

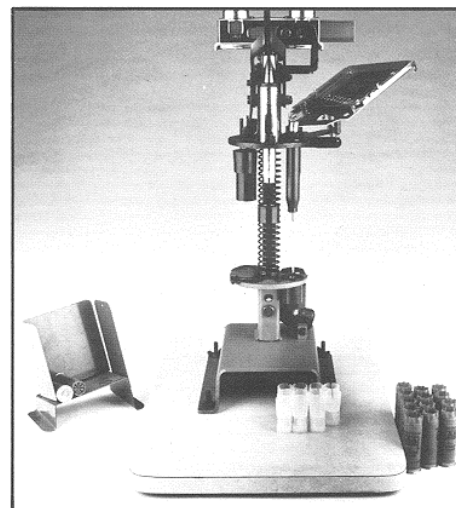

Photo No. 5

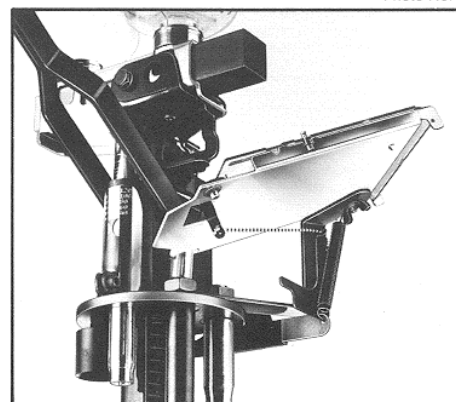

Photo No. 6

As you face the loader you will see the measure Photo #2. On this measure you will see (shot) on the left and (powder) on the right. Remove charge bar to the right and remove the disk covering the powder bushing hole. Now place the proper bushing into the charge bar. move the bar to the left and replace the Pro Check. After making sure that the neoprene grommet Part #304G is in place in the measure Photo #9 you may turn a plastic container into each of the threaded cups. Now move the charging bar to the extreme right and after removing the cap plug in each bottle, fill with the proper powder and shot. Replace the cap plugs and you are ready to load. You will note that the measure will tilt to the rear for easy removal of your shot and powder Photo #11. Note the #10/24 screw on which the measure pivots should be kept tight enough so that some resistance is felt when tilting the measure. Overtightening will crush the bracket. Note: Use the larger container for shot and the small container for powder.

Common sense precautions are advised. Careless handling of flammables and explosives can result in serious injury. We endorse checking charges with a reliable scale which will disclose variations in powder weights. Adhering to loads recommended by the powder manufacturer is a must and the use of safety glasses is strongly encouraged. We disclaim any liability for damage or injury resulting from reloading shot shells.

We disclaim any liability resulting from the use of any parts or accessories not manufactured or recommended by MEC.

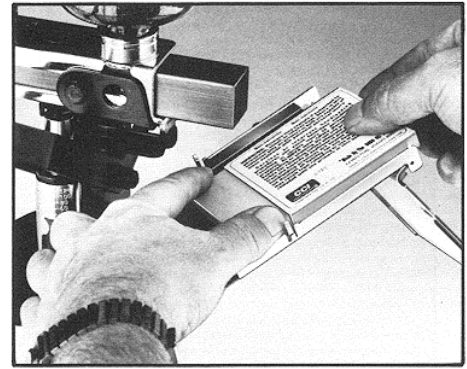

Photo No. 7

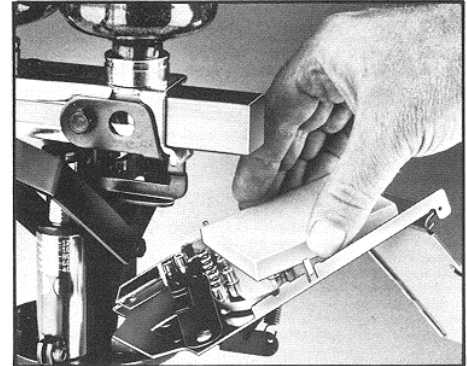

Photo No. 8

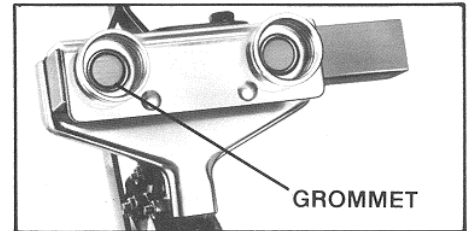

Photo No. 9

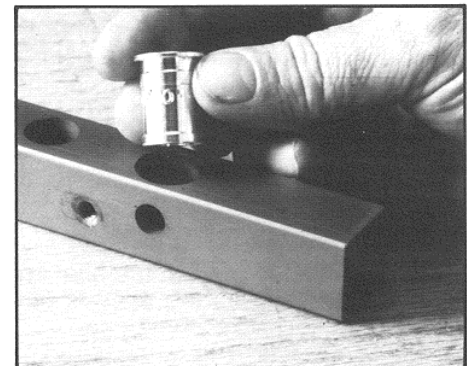

Photo No. 10

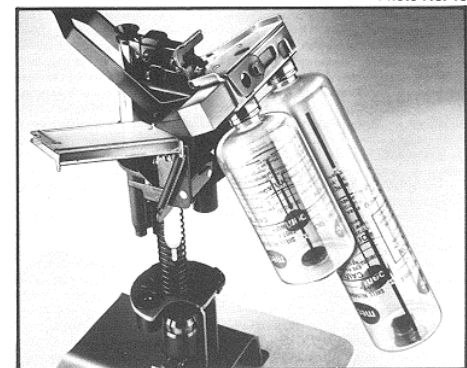

Photo No. 11

LET'S START RELOADING

You will note that your shells are processed in a clockwise rotation starting at the resize deprime station Photo #12 position #1 moving to the reprime station #2 to the powder wad and shot station #3 then moving to the crimp start station #4 and final crimp in station #5.

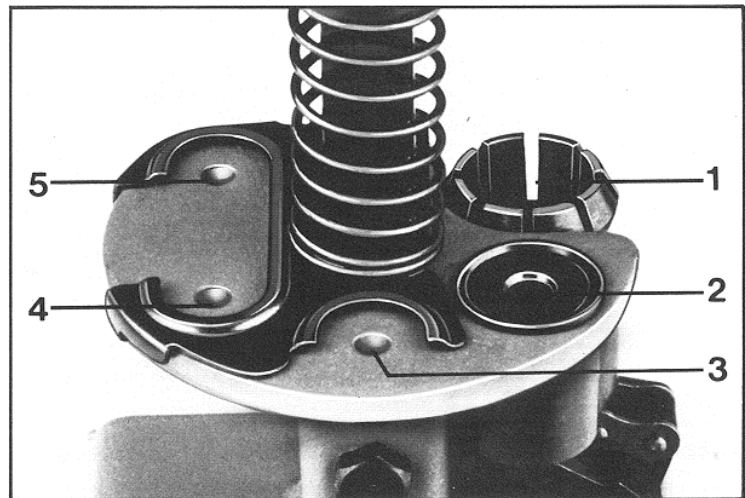

Photo No. 12

STEP ONE

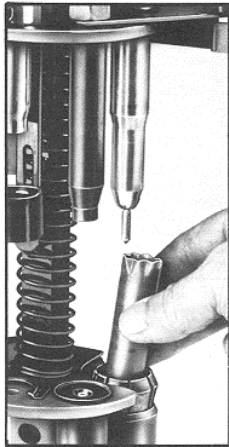

Photo No. 13



Photo No. 14

Take an empty shell in your right hand and place it into the deprime resize station Photo #13. With your left hand depress the handle to the bottom of its stroke. Make sure that the handle is depressed to the full bottom of its stroke or you will not remove the primer or completely resize the shell. Now lift the handle to the full top of its stroke. Again with your right hand remove the shell from the resize station and place this shell onto the reprime punch Photo #14. At this time a primer should be in the reprime pocket station #2 Photo #12.

STEP TWO

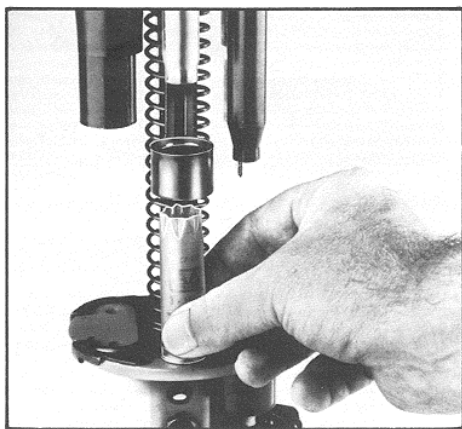

Photo No. 15

Again with your left hand depress the handle until the primer is firmly seated. Use no more pressure than is needed to seat the primer level with the bottom of the shell.

While raising the handle with your left hand remove the reprimed shell from the reprime punch with your right hand and place it into the shell holder at station #3 Photo #15.

STEP THREE

Now depress the handle with your left hand. It is only necessary to depress the handle until the rammer tube #505B in Photo #16 enters the shell. Hold the handle in this position and with your right hand move the charging bar #302 in Photo #16 to the left thus charging with powder.

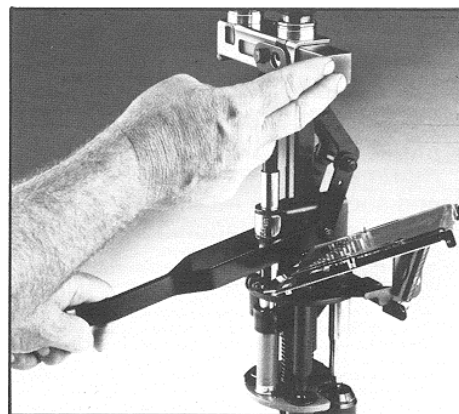

Photo No. 16

STEP FOUR

Now with your left hand lift the handle to the top of its stroke. Now place a wad on the rammer tube Photo #17. With your left hand again depress the handle to the bottom of its stroke.



Photo No. 17

STEP FIVE

At this point change from your left hand to your right hand and lift the handle so the rammer tube is still in the shell as in Photo #18. Now with your left hand move the charging bar #302 in Photo #18 to its full right position, thus charging with shot.

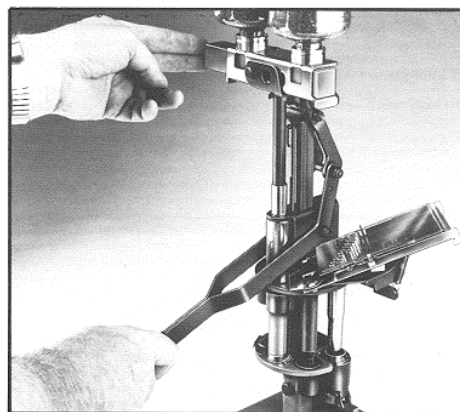

Photo No. 18

STEP SIX

Now lift the handle to the top of its stroke and with your left hand place the shell into the crimp start station #4 Photo #19. With your right hand again depress the handle to its full bottom position starting the crimp. Note that this crimp starter may be adjusted up or down by loosening the nut on the stud that retains the spindex. To remove or change the spindex, simply pull down to remove and snap the new one in place. A properly started crimp should look like Photo #20. The adjustment as it came from the factory should be correct for most skeet and trap loads except for 28 gauge and .410 are 8 point crimp. Many field loads may be 6 point. It is important that shells are crimped with the same crimp as original. A smooth cone is available for crimping paper shells.

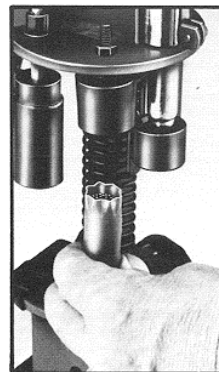

Photo No. 19

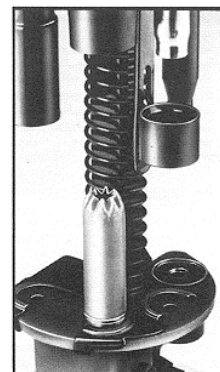

Photo No. 20

STEP SEVEN

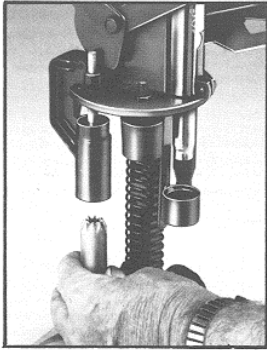

Photo No. 21

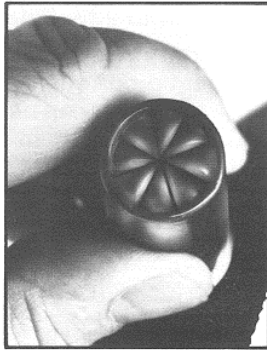

Photo No. 22

Again with your right hand raise the handle until the shell can be moved to the crimp station #5 Photo #21. With a smooth motion bring the handle down to the bottom of its stroke closing the shell. Raise the handle to remove the shell.

By following these instructions exactly you will develop the correct hand movement and with practice should load 6 to 10 boxes of shells per hour.

A properly crimped shell should look like the shell in Photo #22.

LOADER ADJUSTMENTS

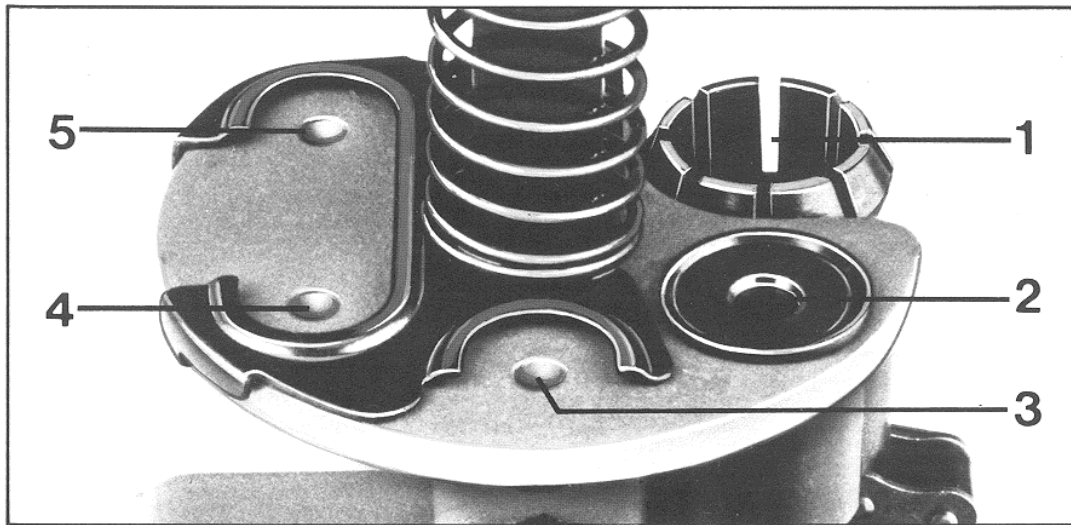

Photo No. 23

Station #1: Deprime and resize adjustment of the collet. Remove the shot and powder from the machine. Now remove the machine from its mounting. Under the base you will find a $\frac{13}{16}$ nut that locks the collet. Loosen this nut and the collet is now free to turn. To make the shell smaller, the collet must be turned clockwise. Do not size the shell any smaller than is necessary to fit freely into the chamber of your gun. After getting the proper size, tighten the locknut, replace the loader on its bench or board, put the shot and powder back, and resume loading.

Station #2, Photo #23. Reprime Station

There are no adjustments on this station. A word of caution however: If too much pressure is used after the primer is seated, it is possible to bulge the case.

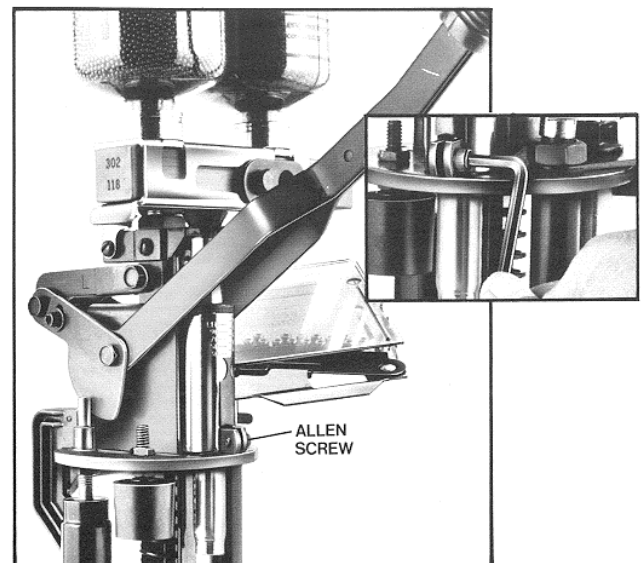

Photo No. 24

Station #3, Photo #23. Powder Wad and Shot

There is one important adjustment to be made at this station and that is the wad height or wad pressure adjustment. Photo #24 shows the wad pressure indicator, the adjusting screw and the wad height indicator. With the modern plastic wads it has become unnecessary to put pressure on the wad. All that is required is that the wad is seated firmly against the powder. It is not necessary for the indicator (C) Photo #2 to move when seating the wad.



Photo No. 25

The wad height indicator marks (B) Photo #2 are for reference only. This adjustment is used to compensate for different shot loads and different wad pressure when needed . . . To make the adjustment, loosen the allen screw in Photo #24. Now the tube in Photo #24 is free to move up or down. In all cases the adjustment should be placed so that the correct wad height or wad pressure is obtained at the full bottom of the handle stroke. Moving the tube down decreases wad height and increases wad pressure. Raising the tube increases wad height and decreases wad pressure. Many times a poor crimp (one which is caused by the wad being too high or too low) can be improved by raising or lowering the wad height indicator. The wad guide if damaged is changed by forcing it up in the slot which supports it. Put a new one in the slot and force it down. Photo #25

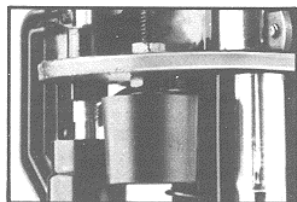

Photo No. 26

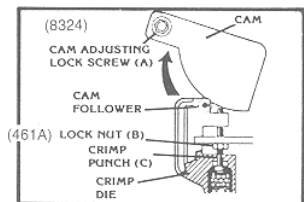

Photo No. 27

Station #4, Photo #23. Crimp Starter

Your new Sizemaster has a new Spindex which when properly used will almost never misfold.

The Spindex may be removed by pulling down. Replace by pushing up. The nuts on the stud are for adjusting the spindex up or down to give more or less of a crimp start Photo #26. Changing the crimp start more or less will sometimes improve a final crimp. It is necessary to put the same crimp on a shell that it originally had. If you wish to crimp paper shells, a smooth cone crimp starter is available.

Station #5, Photo #23. Final Crimp

As your loader comes from the factory the adjustment should be correct for most shells. There are two adjustments that can be made in the final crimp station. They are the cam adjustment Photo #27 and the punch adjustment Photo #27. Four of the common problems which can be corrected by crimp station adjustments. Photos #28-31.

Shell #1 – Crimp punch not deep enough. Correct by loosening lock nut #461A and turn punch deeper.

Shell #2 – Crimp punch too deep. Correct by loosening lock nut #461A and raise crimp punch.

Shell #3 – Opening in center of shell. Correct by loosening cam adjustment bolt #8324 and moving cam down about 1/32 of an inch and try again.

Shell #4 – Shell has a swirl in the crimp. Adjust by loosening cam adjust screw #8324 and move the cam up, as shown by direction of arrow. Move about 1/32 and try again.

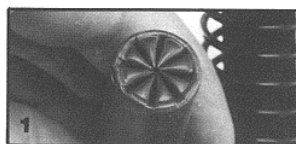

Photo No. 28

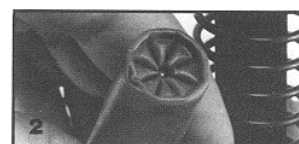

Photo No. 29

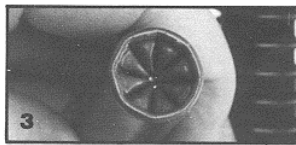

Photo No. 30

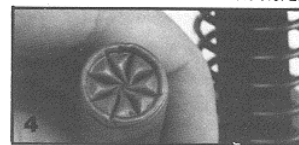

Photo No. 31

Pivot points (1-2-3) of the scissor linkage and the chain link and pivot pin (4) of the closer assembly are to be oiled periodically on both sides. our choice is EP90 or its equivalent (heavy oil). The column, in the area that the turret slides must be kept lubricated. (Heavy oil "A") We *DO NOT* like to see spray lubricants used on the reloader. These sprays cause a buildup of residue over the entire loader.

The roller on the cam crimp die and the roller in the actuator rod (5) should be kept lightly greased.

Occasionally feel the inside of the cam crimp die. if you should notice any buildup of dirt or residue, it can be removed using a swab with any household cleaner.

THE OUTSIDE OF THE EIGHT COLLET SEGMENTS (6), in the area where the collet closer bears against the collet, must be GREASED. We have not found an oil or spray lubricant satisfactory. We prefer Antiseize lubricant, a product of Loctite or a graphite impregnated grease (Outers Gunslick or its equivalent) (GREASE area 6). Lack of lube on the collet will result in additional effort required on the down stroke and possible damage to the unit when the closer is forced away from the collet on the up stroke. The inside of the collet and the shell lifter must be kept *Clean and Dry*.

Cleanliness is not a virtue, it's a necessity for efficiency. Wipe the primer tray with a tissue or silicon cloth to allow the primers to slide freely. Powder residue is abrasive and flammable, don't allow an accumulation. Shot should be in the container or in the shell. The results of loose pellets found under a bare foot, in your wife's shag rug or in the reloader mechanism will, in some manner, adversely affect your efforts.

A little care for a lot of service.

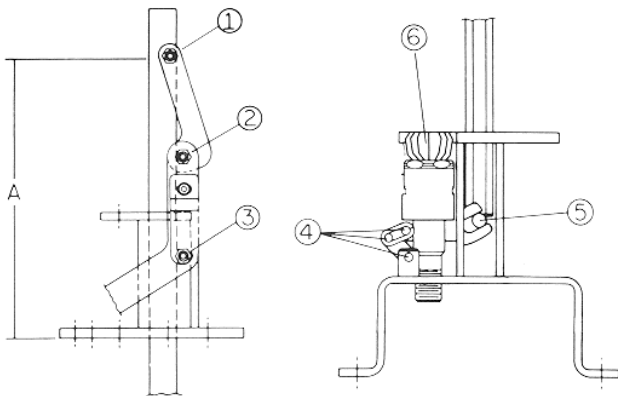

3 INCH SHELLS

If you are not going to process large numbers of 3-inch shells, the easiest way to do them is: Start by resizing and depriming the shells. Do this to all the shells that you intend to load. Now make the column adjustment and place the spacer under the primer seating assembly. Now you can finish loading the shells in the standard way.

The column adjustment is made by removing column bolt (Photo #33), raise the column 1/4-inch and replace the bolt in the top hole in the column and the top hole in the base.

If large numbers are to be loaded, it is necessary to remove the deprime punch, put spacer #8126 (Item M – Photo #3) on it, and replace. Also on the back of the machine Photo #34 the bolt and roller must be moved down to the 3-inch position.

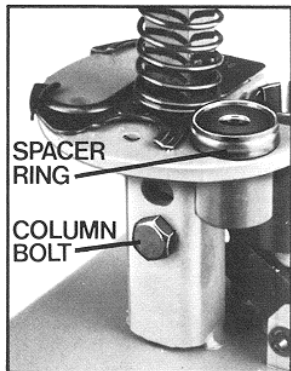

Photo No.33

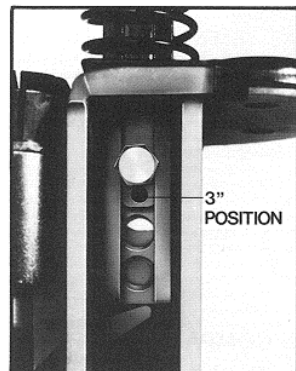

Photo No. 34

After the column has been raised to accommodate 3" shells, remove the primer seating assembly from the base and slip primer seating spacer ring #8111 (Item K – Photo #3) onto the primer seating cup and replace. This has now raised the primer seating assembly 1/4" to accommodate 3" shells Photo #33.

IF YOU HAVE TROUBLE

1. Oversize shells

A shell that goes into your gun hard but comes out easy is caused by oversize plastic or paper.

In the case of plastic shells, overfilling is almost always the cause. To correct you need:

1. A case with more capacity
2. A shorter wad
3. Less shot
4. A more dense powder
5. Sometimes using more wad pressure will give more room in the case.

Over or under filling is most often corrected by using the proper size wad.

If using paper shells, any of the above can be the cause but the most common cause with paper shells is to swell up by absorbing moisture. The only way to remedy this is to dry the cases before reloading.

Never attempt to dry loaded cases. Putting them in the oven at about 200° for 30 minutes will usually dry them. Don't even attempt to load paper cases during hot humid weather.

A shell that goes into your gun hard and comes out hard is caused by oversize brass. To correct:

Adjust the collet per station #1 instructions.

Case bulges above the brass:

When a case bulges above the brass, it is usually caused by overfilling the case. To correct:

1. Use a case with more capacity
2. Use a shorter wad
3. Use less shot
4. Use a denser powder
5. Use more wad pressure (40# is usually sufficient).

Can also be caused by cam adjustment or punch adjustment being too low (refer to adjustment instruction #5 for correction).

Poor Crimps

1. Hole in crimp
Refer to punch and cam adjustment.
2. Misfolded crimps
Using wrong crimp starter 6 or 8 point.
3. Swirl in crimp
Caused by cam adjustment down too far, refer to cam adjustment #5.

Measure sticks when dropping shot. Some of the causes are:

1. Large shot sizes (larger than #6)
2. Grommets worn
3. Reclaimed shot (contains small stones and no graphite lube)

When using large shot sizes, it usually works better to remove the grommet from the shot side of the measure. Moving the bar gently and reversing the action when resistance is noted usually works.

Shot lodges in tubes and will not drop into shell.

This can be annoying particularly in the small gauges because of the small tube diameters when using heavy shot.

It is best prevented by raising the handle to the point where the rammer tube is just in the shell and moving the charge bar across very slowly so the shot does not all drop at one time.

Powder Leaks From Measure

Usually caused by not having brass washer in place when using Winchester Powder.

This washer is placed under the grommet with the smooth side down.

Steel Shot.

This reloader will load steel shot.

Lead and steel are not interchangeable.

Kit #8433 is necessary to convert to steel shot. Do not use components designed for lead shot.

Do not use charge bars designed for lead shot. A special bar is necessary for steel shot.

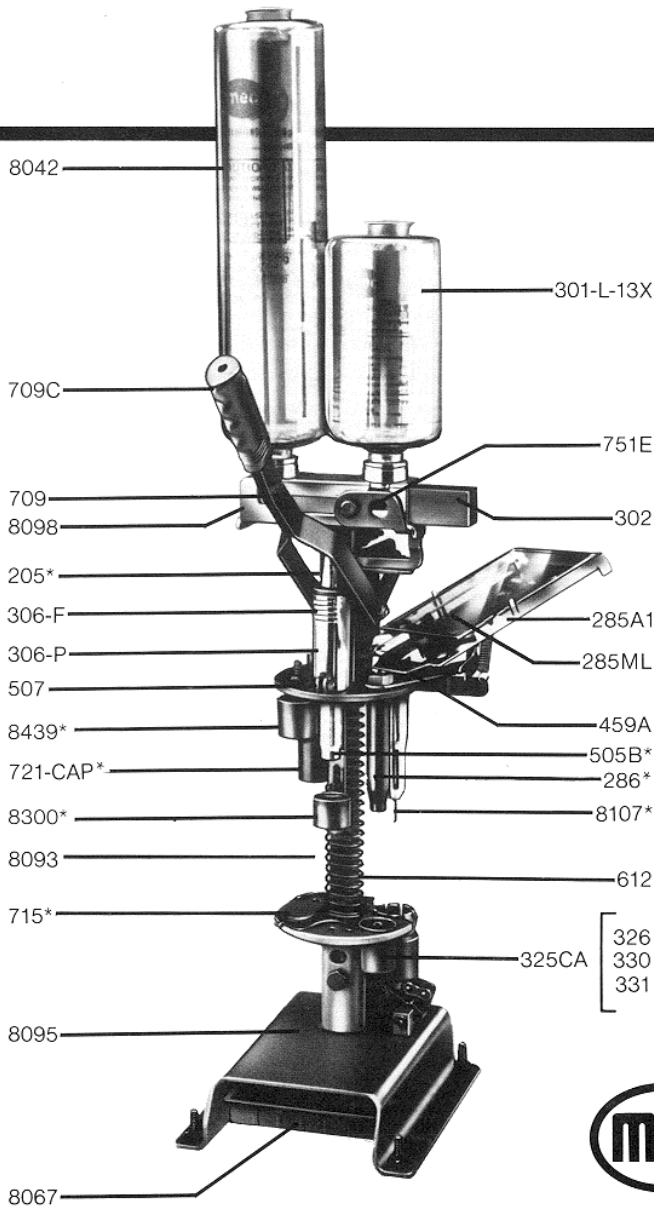

MEC SIZEMASTER PARTS LIST

Part No.	Part Description
205*	Drop Tube
285A1	Primer Tray
285ML	Cover
286*	Reprime Punch
301-L-13X	Powder Container
302	Charge Bar
306-F	Pressure Ind. Face
306-P	Pointer
325CA	Primer Seating Assembly
326	Primer Cup
330	Spring
331	Spring Pad
459A	Lock Nut
505B*	Rammer Tube
507	Adjusting Clamp
612	Column Spring
709	Handle
709C	Handle Grip
715*	Shell Holder
721-CAP*	Cam Crimp Assembly
751E	Pro Check
8042	Shot Container
8067	Primer Catcher
8093	Column
8095	Base Assembly
8098	Measure Assembly
8107*	Deprime Punch
8300*	Wad Guide Fingers
8439*	Spindex Star Crimp

SIZEMASTER Accessory Equipment

8165*-10-12-16-20-28-.410	Die Set
---------------------------	---------

*Specify gauge.



MAYVILLE ENGINEERING COMPANY, INC.

An Employee Owned Company
 715 South Street • Mayville, Wisconsin 53050
 Phone (920) 387-4500 • FAX (920) 387-5802



Printed in U.S.A.