

SHOTSHELL RELOADING WITH THE



MEC 650™

The Reloader With a Memory

Mayville Engineering Company, foremost manufacturer of reloading equipment in America, is widely respected for its continuing dedication to precision engineering.

This precision is incorporated into every one of MEC's "New Generation" reloaders, rendering truly innovative and efficient engineering designs.

The MEC 650 Progressive Reloader gives maximum performance with a minimum of effort. The MEC 650 works on 6 shells at one time. With every stroke of the handle a perfectly reloaded shell is completed.

The MEC 650 has three crimping stations. The first station starts the crimp with the exclusive one piece Spindex™ crimp starter with swivel action to correctly align with the original shell creases. Second, it closes the crimp and third it places a taper on the shell which is so important for proper feeding in a pump or automatic.

MEC reloaders come completely assembled, tested and ready to use...without adjustment. With the many features engineered into the MEC 650, it is the finest reloader on the market and will provide years of reloading pleasure.

This reloader will allow you to reload with steel shot. To convert to steel shot, Kit No. 8581 is necessary.

A special steel shot charge bar must be used when loading steel shot. Do not use charge bars designed for lead shot when loading steel shotshells.

Common sense precautions are advised. Careless handling of flammables and explosives can result in serious injury. We endorse checking charges with a reliable scale which will disclose variations in powder weights. Adhering to loads recommended by the powder manufacturer is a must and the use of safety glasses is strongly encouraged. We disclaim any liability for damage or injury resulting from reloading shotshells.

We disclaim any liability resulting from the use of any parts or accessories not manufactured or recommended by MEC.

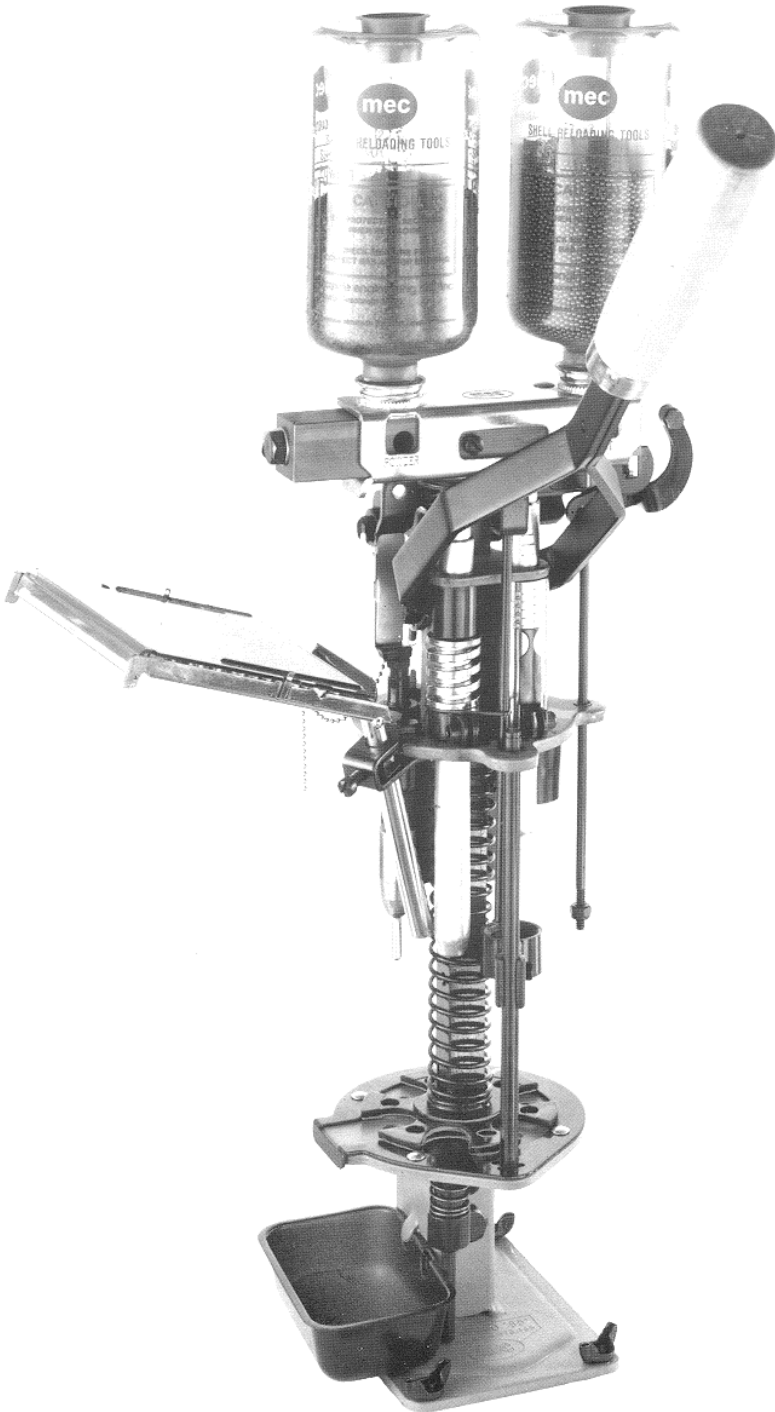

LET'S LOOK INSIDE A SHOTSHELL...

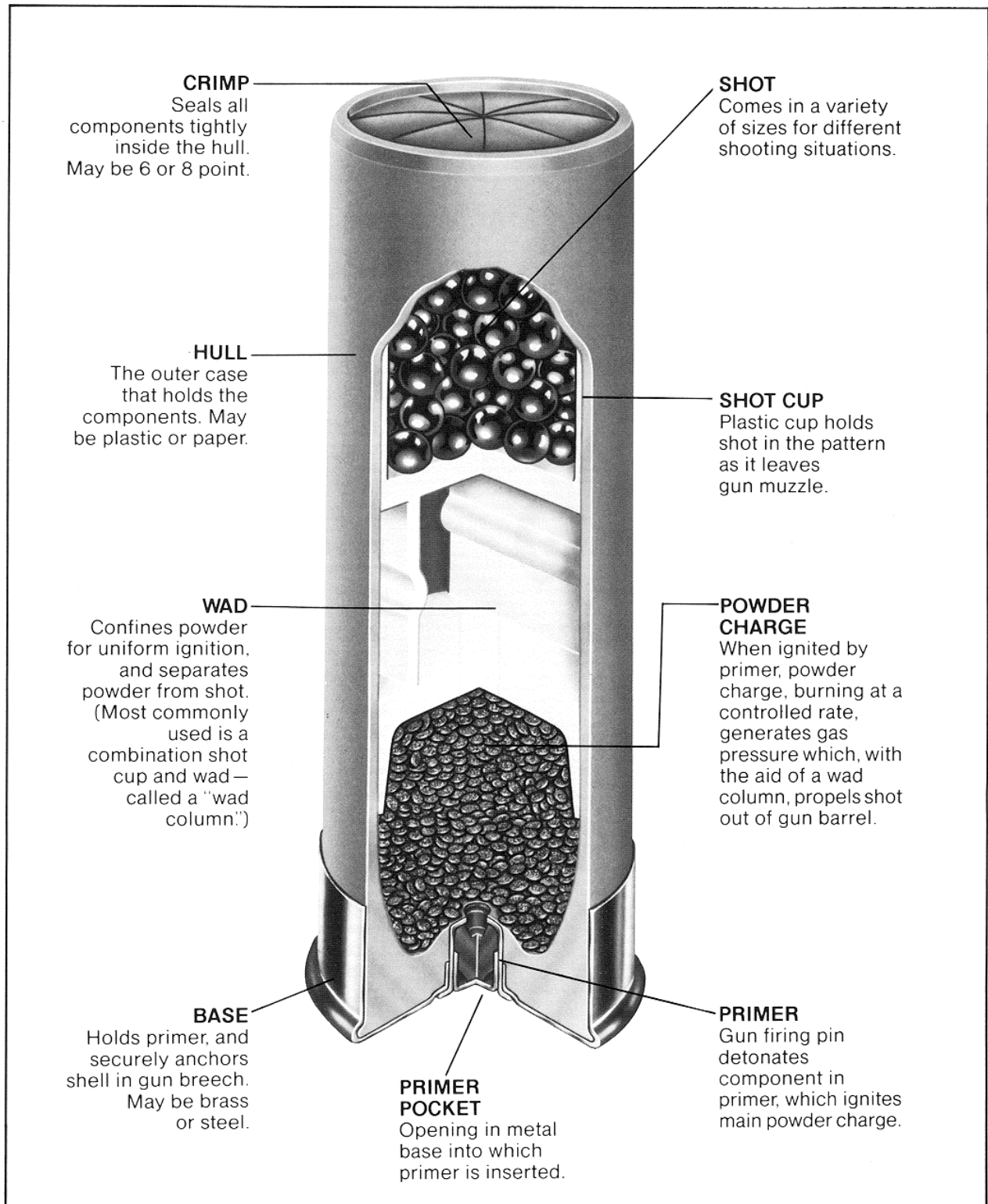

Photo No. 1

HOW TO SELECT COMPONENTS

As we saw on the previous page, a shotshell is made up of several different components. There are many different variations of each component.

Packed with every MEC reloader are brochures supplied by leading component manufacturers. A study of this literature will show you numerous combinations of primer, powder charge, wad and shot you should use with each empty hull, for waterfowl, small game, or trap and skeet. Each combination of components has been carefully tested by ballistics experts for maximum effectiveness and safety. ***Experimenting with combinations not recommended by a component manufacturer is foolhardy and dangerous!***

Choosing the Hull.

Proper choice of empty hulls is one of the most important choices you must make to keep your reloading simple.

The problems encountered by trying to use any and all of the hulls you may find are usually quite discouraging. Not all hulls have the same capacity. Not all hulls have the same crimp. Each time that you use a hull with a different capacity (usually caused by different base wad height) you must assemble a different set of components to properly fill this case.

We are not recommending that you throw away all the nonstandard hulls that you have but are advising you to keep it simple until you have gained the experience necessary to assemble the different components.

Selecting the Right Wad.

The wad is that part of the shotshell between the powder and the shot. A tight seal permits the expanding gas from the burning powder to push the shot column out of the gun barrel with maximum velocity.

Modern "wad columns" combine both the shot cup and the wad in one piece. These one-piece wad columns are the easiest to use, and therefore are most popular—especially with beginning reloaders. There are many different kinds. Use only the specific wad column recommended for the other components you are using.

The Shot.

There are two kinds of shot—lead and steel. **Lead and steel shot are not interchangeable.** Reloading with steel shot requires special wads. Using wads designed for lead shot will not only ruin your gun, but could cause high pressures that could burst the gun causing injury or death to the shooter or bystander.

When loading with steel shot, it is imperative that steel shot components be used and the instructions for these components be followed to the letter. Only select components that are suited for steel shot reloading.

As the size of the shot increases, fewer pellets can be loaded into the hull. The smaller sizes are used for trap and skeet, doves, varmints, small game, etc. The larger shot sizes are for heavier game—ducks, geese, turkeys, etc.

SHOT SIZES

(Shown Actual Size)

Lead Shot		Buckshot	
No.	Dia.		
9	● .08"	4	● .24"
8½	● .085"		
8	● .09"	3	● .25"
7½	● .095"		
7	● .10"	1	● .30"
6	● .11"		
5	● .12"	0	● .32"
4	● .13"		
2	● .15"	00	● .33"
Air			
Rifle	● .175"		
BB	● .18"		

All Powder Is Not Alike.

Different powders have different burning speeds, which make them useful for different jobs. The heavier the shot load, the slower the powder must burn. It takes longer to accelerate a heavy shot load than it does a light one.

A fast-burning powder ignited behind a heavy shot load could cause excessive "breech pressure" which might cause damage to the gun and even injury to the shooter or bystander. (Breech pressure is the pressure of the gas which is created by the burning powder. It is this breech pressure which forces the shot through the barrel.)

On the other hand, using a slow-burning powder to propel a light load of shot will not work effectively. Without the proper pressure buildup, many powders will not burn uniformly and impart sufficient velocity to the shot. ***Never*** interchange powders for reloading steel shot. A powder that generates acceptable pressures on 1½ oz. of lead shot cannot be used to propel 1½ oz. of steel shot. The pressures will raise to dangerous levels.

Which Primer to Use?

The primer ignites the powder. When you pull the trigger, the hammer falls on the firing pin, denting the primer cup. This causes the component in the primer to detonate, igniting the main powder charge.

Different primers have different characteristics depending on their purpose. Use only the primer that is recommended by the component manufacturer for the hull, powder, wad, and shot load you are using.

To make reloading safe, all it takes is common sense and the ability to read and follow the directions of the various component manufacturers.

When you purchase your powder, get a copy of the "SAAMI" (Sporting Arms and Manufacturers Institute) pamphlet on the properties and storage of smokeless powder. Read this literature and abide by it. Generally speaking, powder is safer than gasoline, because unlike gasoline, it does not give off explosive fumes. If ignited, powder will burn until it consumes itself. Modern smokeless powders must be confined to cause an explosion. The containers that powder is purchased in are designed to burst without causing an explosion if the powder is accidentally ignited. Your powder should be kept in these containers until it is used up. It is unsafe to put powder in a glass jar or bottle or any other container which could cause pressure buildup. Store your powder where there is no chance of sparks, fire or flame, where it is cool and dry, and where children cannot reach it.

Primers also require care in handling. Never take primers from the container that they come in until ready for use. Storage of primers in anything but the container

that they were purchased in is unsafe. Exposing a primer to excessive heat, or to fire, flame or rough handling will cause it to explode. Do not store primers near your powder or where children can get at them.

When a manufacturer tells you to use a particular set of components in a shell it means precisely that. You cannot indiscriminately experiment with or substitute components without experiencing problems. At best, you will get a shell which fails to give the performance you expect. At worst, you may inflict serious injury upon yourself or someone else who fires your reloaded shells. The manufacturer has extensively tested recommended loads and knows how they perform. Always follow these recommendations exactly.

It is also highly recommended that safety glasses be worn when reloading.

When finished reloading, remove the containers from your machine and seal them with caps and put them in a safe place. Also return all primers to their original container and store them in a safe place. It is important that these materials are kept out of the reach of children and other unauthorized persons.

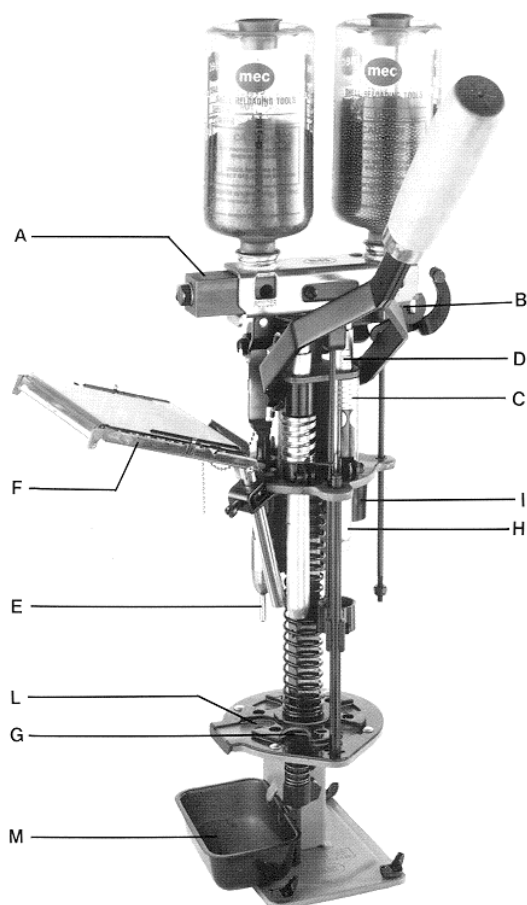

Photo No. 2

After removing your new reloader from its carton, inspect it carefully for damage. In addition to the reloader itself, you should have these additional parts shown in Photo #3.

Before you actually try reloading, we recommend that you look over your loader and compare it with this diagram identifying all the parts and dies you'll be using.

- A. CHARGING BAR is located just under the powder and shot containers.
- B. AUTOMATIC-CYCLE MECHANISM. Each stroke of the handle automatically moves the charge bar to left or right measuring and charging precise amounts of powder or shot into the shells.
- C. WAD PRESSURE INDICATOR gives exact amount of pressure actually being applied to the wad column at the bottom of the handle stroke.
- D. WAD HEIGHT INDICATOR used to disclose improper wadding.
- E. DEPRIME at which the shell opening is ironed and spent primer is ejected.
- F. AUTOMATIC PRIMER FEED positions primers in shell carrier with each stroke of the handle.
- G. REPRIMING STATION at which shell is also charged with powder. Spring tension automatically applies the proper pressure and compensates for variations in height of base wad while seating primer.
- H. RAMMER TUBE is used to seat the wad column and through which shot is also dropped into the shell.
- I. SPINDEX™ CRIMP STARTING with swivel action to correctly align with the original shell creases. Can be changed from 6-8 pt. in seconds.
- J. CRIMPING STATION with the exclusive cam-operated two stage crimping apparatus. Die is adjustable for depth of crimp. (Not Shown)
- K. RESIZING AND FINISHING STATION radius may be adjusted to suit individual taste. (Not Shown)
- L. SHELL CARRIER into which shells are placed and which automatically position each shell at the proper station.
- M. PRIMER CATCHER which is secured into position at the base.

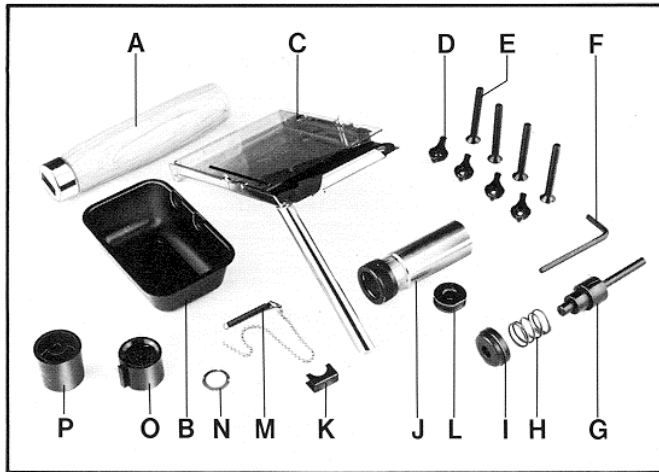

Photo No. 3

Contents of Parts Bag

- | | |
|------------------------|---|
| A. Handle | J. Resizing Ring/Support Tube |
| B. Primer Catcher | K. Retaining Clip |
| C. Primer Feed | L. Resize Adapter |
| D. Wing Nuts | M. Primer Feed Spring |
| E. Bolts | N. Brass Washer |
| F. Allen Wrench | O. Extra Wad Guide |
| G. Primer Seating Post | P. Spindex Crimp Starter – 6 pt.
(12 - 16 - 20 gauge only) |
| H. Spring | |
| I. Spring Pad | |

(g,h,i) assemble as shown Photo #17.

(N) Brass washer is used on fine grained powders (Winchester) to prevent leaking. Install on the powder side of the measure by removing the grommet. Photo #10.

MOUNTING YOUR RELOADER

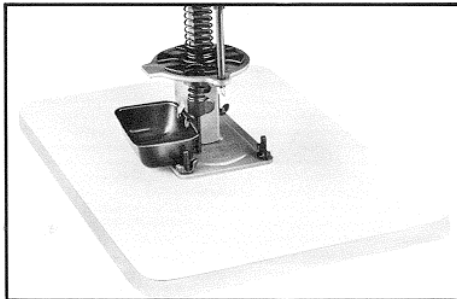

Photo No. 4

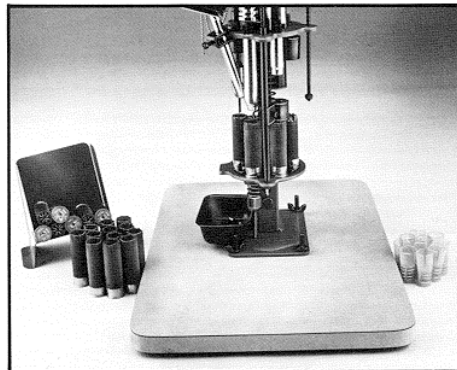

Photo No. 5

Although it is desirable to have your reloader mounted permanently to a bench, it is not a necessity. However, if you do mount your reloader on a bench, allow sufficient room to tilt the measure back as in Photo #6. If you cannot mount your reloader permanently to a bench, we recommend placing your reloader on a piece of $\frac{3}{4}$ x 12 x 18" plywood. Photo #4 shows the ideal location for your loader on a piece of plywood. Install your reloader by placing it in the proper location, marking through the holes with a pencil, then remove your reloader and drill a $\frac{9}{32}$ hole at these locations. Put the reloader back in position and fasten securely with the $\frac{1}{4}$ x 20 x 2" counter sunk stove bolts with wing nuts. Place the bolts in from the bottom up and draw them up tight enough so the heads are slightly depressed so that they will not scratch the bench or table.

By this time you should have made your choice of components. Photo #5 shows how these components should be placed for the most efficient operation of your MEC 650.

You will note that the measure will tilt to the rear for easy removal of shot and powder containers, Photo #6. Note: The screw on which the measure pivots should be kept tight enough so that some resistance is felt when tilting the measure.

Installing the wood handle grip.

Drive handle onto lever up to the mark on the side of the handle, Photo #7.

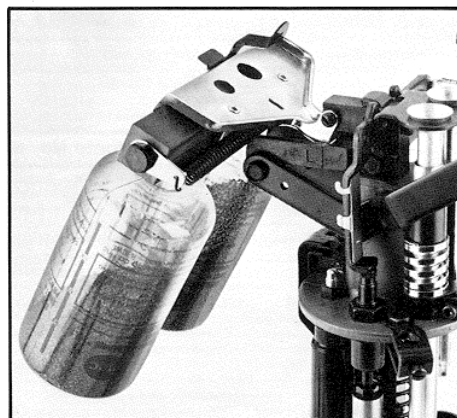

Photo No. 6

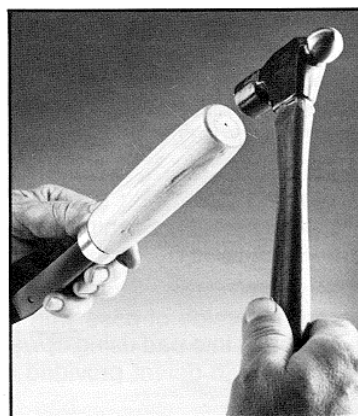

Photo No. 7

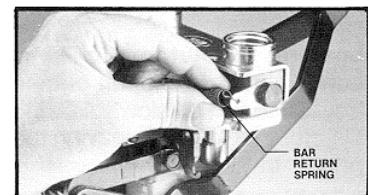

Photo No. 8

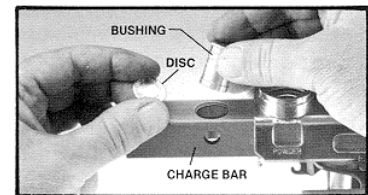

Photo No. 9

MEASURE ASSEMBLY

As you face the loader, you will see the measure, Photo #2. On this measure you will see (powder) on the left and (shot) on the right. Remove the charge bar by first disconnecting the spring, Photo #8 and remove the bar screw. Now remove the charge bar by sliding it to the left, Photo #9, Page 5, and remove the disc covering the powder bushing hole. Now place the proper bushing into the charge bar, and replace bar, spring and screw.

After making sure that the neoprene grommet is in place in the measure, Photo #10, you may turn a plastic shot and powder container into each of the threaded cups. Now the charge bar should be locked in position as per Photo #11.

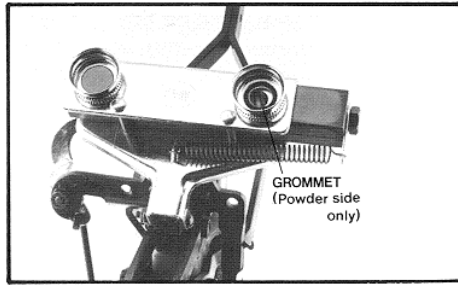

Photo No. 10

Change Notice

Your NEW MEC Progressive Reloader now has an insert in the charge bar on the shot side, which completely prevents all shearing of shot. It is no longer necessary to use a grommet on the shot side as stated in the instruction manual.

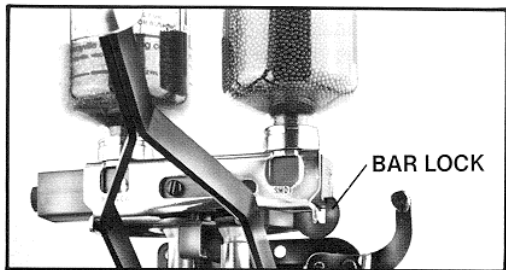

Photo No. 11

Installing the Primer Feed

Remove the primer feed tray from the parts box along with the spring/chain and retaining clip.

Place retaining clip in place, Photo #12. Insert tube into the tube clamp. Now depress handle so that primer tube will rest on the hole provided on the shell carrier, Photo #13. Now tighten screw to hold tube and tray in position. Now hook the spring/chain in position, Photo #14. The spring actuates the primer feed when you depress the handle, adjust the chain position to achieve a positive feed every time. The primer should drop about 1/4-inch from the bottom of the stroke.

Loading the Automatic Primer Feed.

Lower handle and open primer feed cover. Place box of primers on tray. Slide box off slowly, leaving liner and primers on tray, Photo #15. Carefully lift the liner, leaving the primers on the tray, Photo #16. Close primer tray cover.

Installing the Primer Seating Assembly.

Your MEC 650 is equipped with the exclusive self-cleaning primer seating assembly. It consists of 3 parts. Spring pad (A), seating spring (B) and seating post (C). Photo #17.

To Install: Hold spring pad in place on underside of base with left hand. Place spring on seating post and insert into pad using upward pressure. Seat pointed base of seating post in detent provided for this purpose.

To Remove: Simply grasp seating post, lift and pull toward you.

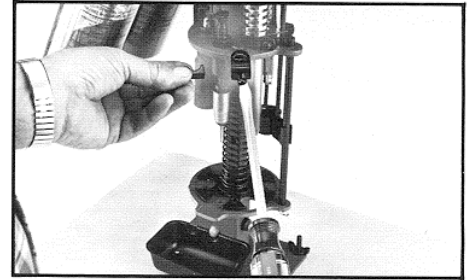

Photo No. 12

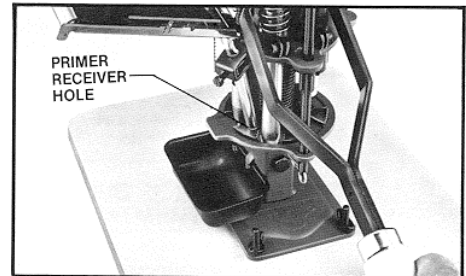

Photo No. 13

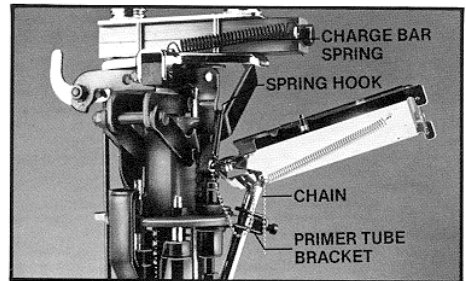

Photo No. 14

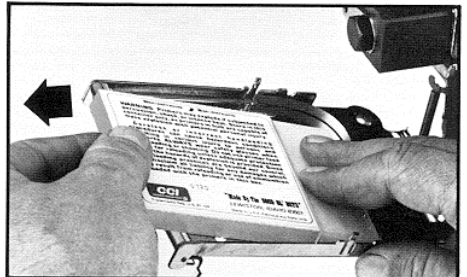

Photo No. 15

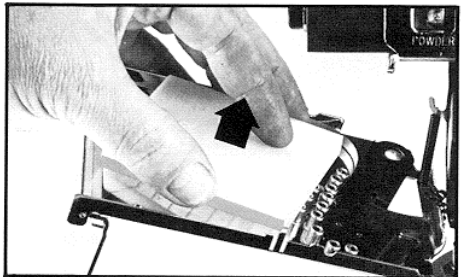

Photo No. 16

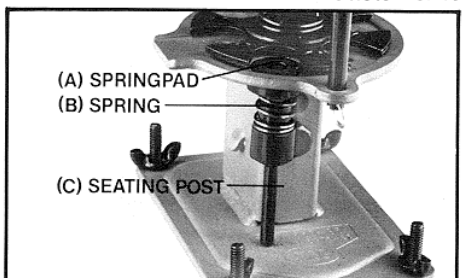

Photo No. 17

LET'S START RELOADING

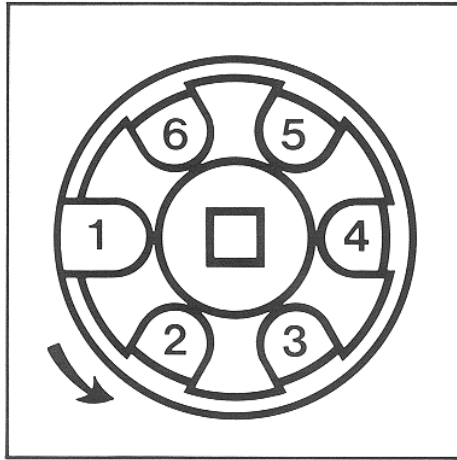

Photo No. 18

Here is a drawing that clearly shows a top view of the six shotshell reloading stations. You will note that your shells are processed in a *counter-clockwise* rotation. In order to explain the reloading sequence step by step using only one shell, and going through each reloading station, we purposely *detached* the automatic primer feed spring from the hook **Note: Manual loading of primer will be necessary while spring is disconnected.**

Move the charge bar to the left as far as it will go and lock it in this position with the bar lock. Photo #11. At this time, you may put the proper powder and shot into their respective containers. Now we're ready to completely **reload a single shell.**

STEP ONE

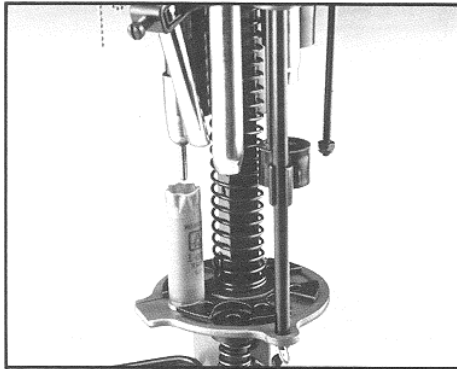

Photo No. 19

Place your empty shell into the carrier at the depriming Station #1, Photo #19 and pull down on the handle with your right hand. This operation deprimes the shell. Now place a primer into primer cup. Next, rotate the six-stage carrier assembly counter-clockwise with your left hand. This is a two-stage motion, with click stop positioning, then position the shell under the reprime tube. Station #2.

STEP TWO

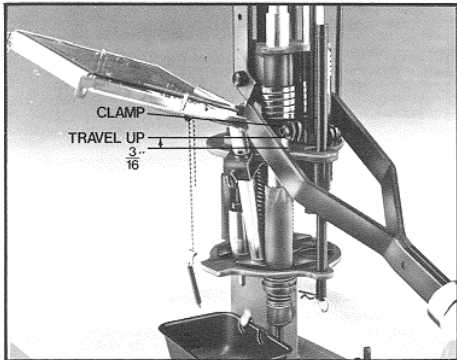

Photo No. 20

Again, with your right hand, depress the handle fully to the bottom of the stroke which reprimed the shell. On the down stroke the charge bar lock lever will automatically unlock the bar *and* on the up stroke the bar will move to the right releasing the proper powder charge into the shell casing. Now move the carrier counter-clockwise two clicks to the next station. Station #3.

STEP THREE

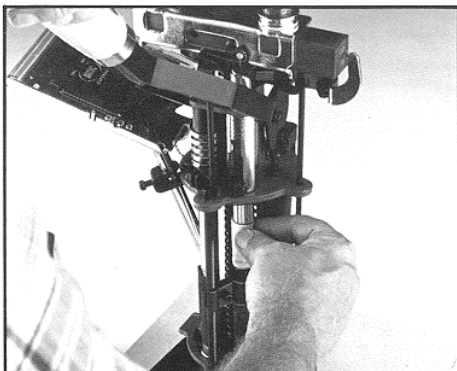

Photo No. 21

Using your right hand, place the proper wad column on the wad ram Photo #21. Important: Do not force wads onto the guide as this spreads the fingers, preventing the wad guide from dropping into position on the shell. By depressing the handle, the wad will be firmly seated, the charge bar will automatically move to the left position and the pre-determined shot charge will drop into the shell.

While visual checking is not necessary, the pointer indicates the exact amount of pressure being applied to the wad column when the handle is depressed. The reading is always positive regardless of any other adjustments. While tool has been pre-set at the factory for average pressure required, you may find it desirable to increase or decrease pressure. Photo #36.

STEP FOUR

Index the shell to Station #4 where the downstroke of the operating handle, the crimp is started with the exclusive spindex crimp starter. Note that this crimp starter may be adjusted up or down by loosening the nut on the stud that retains the spindex and turning these for less or more crimp start.

To remove or change the spindex, simply pull down to remove and snap a new one in place. A properly started crimp should look like Photo #22. It is important that shells are crimped with the same crimp as original, 6 or 8 point.

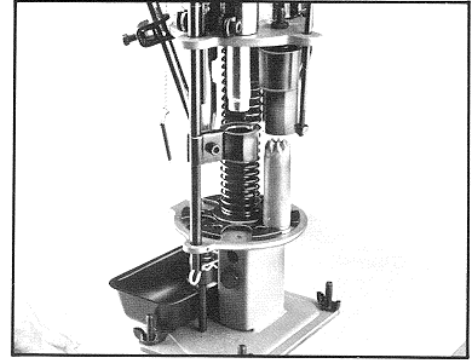

Photo No. 22

STEP FIVE

By rotating the carrier assembly counter-clockwise two clicks to Station #5, we arrive at the closing station. As you depress the handle with your right hand, the crimp punch moves down on the casing and your reloaded shell begins to take on a factory appearance. Photo #23.

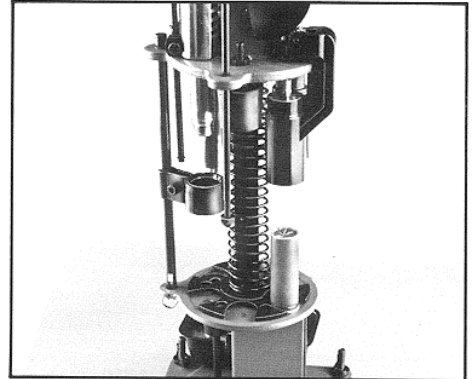

Photo No. 23

STEP SIX

Advance to Station #6 where a pull of the handle resizes and puts a finished radius on the perfectly reloaded shell. Advance the finished shell and remove it from the machine. Photo #25. A properly loaded and crimped shell should look like the shell in Photo #26.

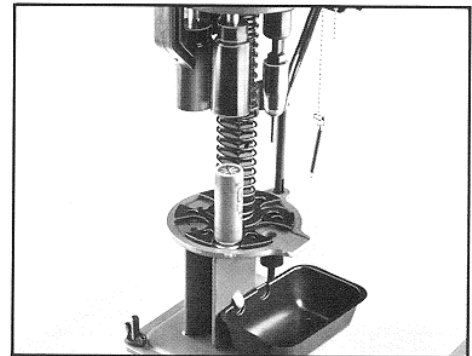

Photo No. 24

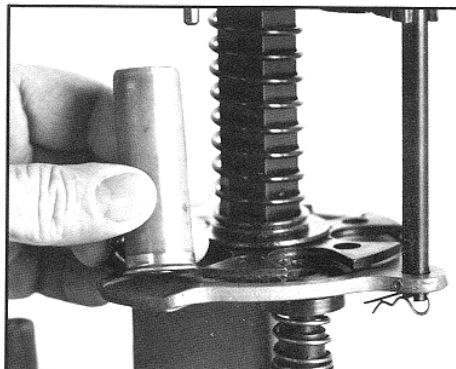

Photo No. 25

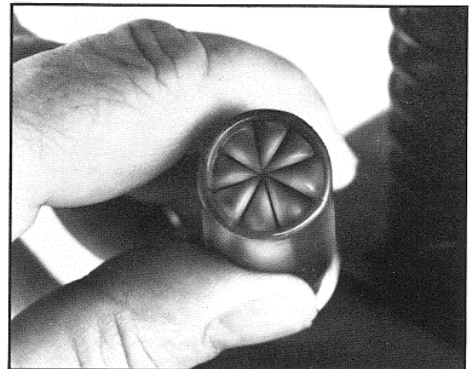

Photo No. 26

AUTOMATIC SEQUENCE

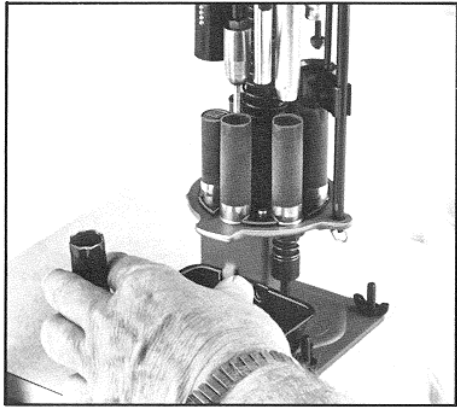

Photo No. 27

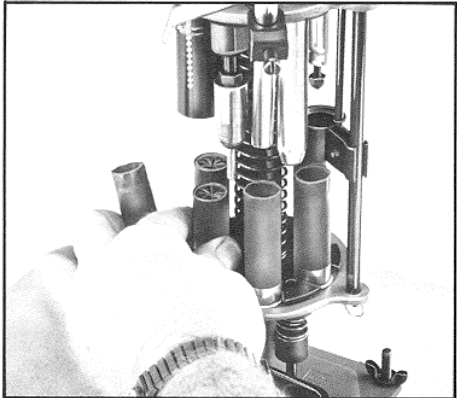

Photo No. 28

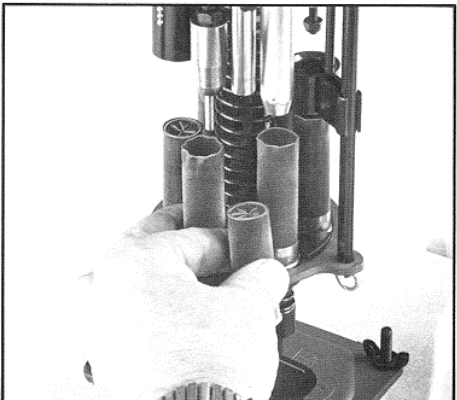

Photo No. 29

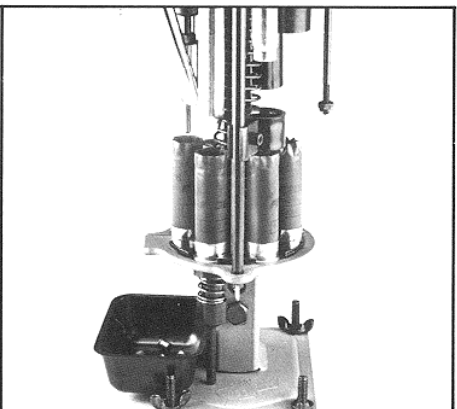

Photo No. 30

Now that we have gone through the loading sequence with one shell, let's proceed with the setup of the automatic sequence that will give us a loaded shell with each pull of the handle. The Model 650 is very easy to operate but attention must be paid to detail, since the misloading of one shell may affect the characteristics of all shells in the press at that time.

First re-hook the primer feed spring. Place an empty shell in the deprime Station #1. **Make certain that the charge bar is locked all the way to the left position by the bar lock, Photo #11, Page #6.** Pull the handle to the down position. This will deprime and place a primer in position.

Move shell carrier counter clockwise a full stop (2 clicks) and insert another empty shell in the No. 1 position. Repeat the procedure, again move the shell carrier one stop (2 clicks) counter clockwise, now insert a wad on the wad column, repeat this procedure each time to obtain a reloaded shell with each complete stroke of the handle.

Follow these instructions exactly and you will develop the correct hand movements to load 10 to 20 boxes per hour.

First pick up the empty shell with your index and middle finger Photo #27. Now remove the loaded shell with your thumb and index finger Photo #28, slide the empty shell into the carrier Photo #29 and place the loaded shell into the E-Z Pak.

To Avoid Mistakes and Problems, It is Necessary to Watch for Certain Things.

1. Make sure that a primer has dropped into the carrier and then into the primer seating assembly as the carrier is advanced.
2. Do not run out of shot, powder or primers. Develop a regular sequence for replacing these components. (Example: Every four boxes of shells, primers must be added — every eight boxes, shot and powder must be replenished.) Also remove the spent primers from under the machine each 400 rounds.
3. Do not mix shells while loading. Process only one kind of shell with matching components. Mixing shells is sure to cause trouble.
4. **Check all shells** for defects, split plastic, cracked brass and foreign objects before placing in machine. Each defective shell processed will probably cause trouble and trouble means "downtime" not only to remove the defective shell but to clean up the mess that it may have caused.
5. **Always** be sure to make a full stroke of the handle. Get accustomed to where the handle "bottoms" and be sure to get a full stroke each time.
6. Anytime that you make a mistake — **stop**. Tip the measure back, lock the bar to the left, unload all shells from the machine, open them and remove the contents before starting over. Do not allow mistakes to get mixed in with good shells. Individual shells may be removed from the machine at any station, tip them to raise the rim above the base and slide them out.
7. **Never** "double stroke" the handle because of an incomplete first stroke, without first checking to see whether any shot or powder has been dropped.
8. If you notice unusual resistance on the downstroke — **stop**. Return the handle to the top of the stroke and locate the problem. **Failure to do so will result in damage to the machine.**

IF YOU HAVE TO RESIZE.

Cases which do not slip easily into shell carrier should be rejected, to be resized as a separate operation after a considerable number have been accumulated. To prepare press for this operation, deactivate primer feed and remove. Remove shot and powder containers.

Screw resizing ring and support tube into position over deprime punch. Now place resizing adapter into carrier Station #1.

Now place an empty shell into position into the resizing ring and depress handle. This will resize the metal portion of the shell back into original dimension. Apply enough force to handle in the upward direction to eject shell from ring.

In some instances, adjustment of the deprime punch may be required to obtain the strike required to strip the shell from the resize ring.

If a great number of cases are to be resized, the **MEC Super Sizer** is recommended.

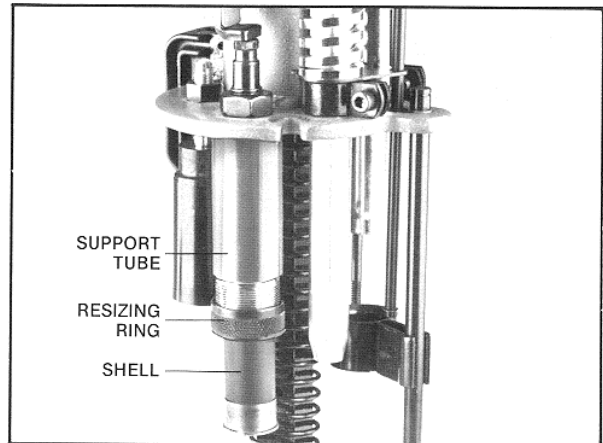

Photo No. 31

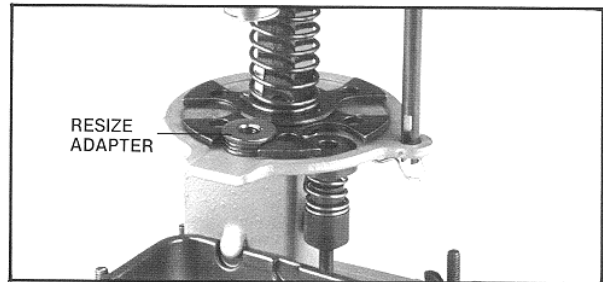

Photo No. 32

3 INCH SHELLS

WITHOUT THIS KIT IT IS NECESSARY TO DEPRIME AS A SEPARATE OPERATION. FOR 12 GAUGE ORDER SPACER KIT #8368, FOR 20 GAUGE ORDER SPACER KIT #8369. THESE KITS ARE AVAILABLE AT NO CHARGE FROM THE FACTORY.

TO ADJUST THE PRESS

1. Move the snap ring on the wad guide rod to the top position. Photo #34.
2. Remove the column bolt. Photo #33. Raise the column $\frac{1}{4}$ inch and replace the bolt. The bolt should be in the top hole of the column and the top hole in the base. Make sure the column is square with the base and retighten.
3. Remove deprime punch by loosening the lock nut just above the punch. Remove the lock nut, and slip spacer (460-10A) onto the eject bolt. Reapply the lock nut and deprime punch positioning the punch at a height that will clear the 3 inch shell.
4. Loosen the bolt that clamps the wad guide in position and raise the wad guide $\frac{1}{4}$ inch. Retighten the bolt. Photo #34.
5. Lower the reprime tube $\frac{1}{4}$ inch. Photo #34.
6. Lower the rammer tube $\frac{1}{4}$ inch or more depending on the wad you are using. . . refer to Photo #36 to adjust the rammer tube.

The press is now ready to process 3" shells!

7. Although the primer feed may be readjusted to the longer shells, most people prefer to feed the primers by hand for the smaller quantities of longer shells.

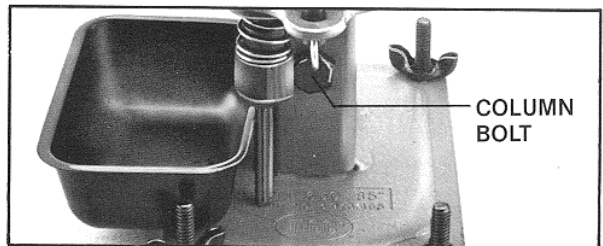

Photo No. 33

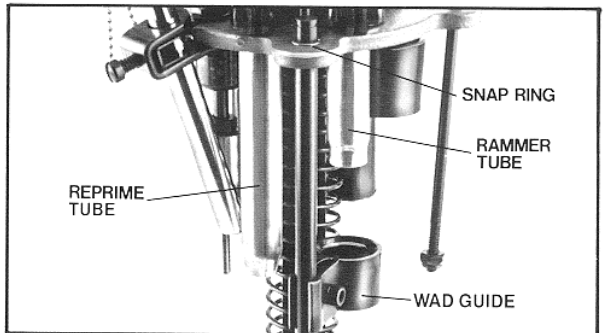

Photo No. 34

FOR 3 INCH .410 GAUGE SHELLS

It is necessary to order Kit #8370.

Follow the above instructions except for #4 where the wad guide must be raised $\frac{1}{2}$ inch.

It is also necessary to remove the crimp die and replace it with the die furnished in the 8370 kit. The nut that locks the crimp punch is now placed above the turret plate rather than below, as with 2 $\frac{1}{2}$ inch shells.

The crimp start and the final crimp die must be raised approximately $\frac{1}{4}$ inch.

ADJUSTMENTS

STATION #2 Reprime.

The only adjustment is to raise or lower the Tube #505 C, to accommodate different base wad heights. With a shell in this position, there should be about $\frac{3}{16}$ inch of travel at the full bottom of the stroke, Photo #20. If you do not have enough travel at this point, the charge bar may not operate or the primer will not be fully inserted. (If this happens, the machine will not index.) Too much travel will raise handle pressure required or cause the clamp to slip. It can also cause the bar not to lock out. To adjust, loosen the Clamp #507, Photo #20, and slide the tube up or down to the required position and retighten.

STATION #3 Shot and Wad.

The MEC Rammer Tube is arranged to provide any wad pressure from 30 to 120 pounds. Using the hex wrench provided, loosen the safety clamp, "A." Set rammer tube to desired position (lower it to increase pressure — raise it to decrease) and tighten clamp. Indicator marks "B" and "C" should be used as a visual aid in making the adjustment. Check your setting by reading actual pressure on gauge face while applying pressure on correct wad column with machine handle in full lowered position. This will always be the actual pressure being applied to wad or wads. When tightening clamp, avoid overtightening. Moderate clamp pressure will hold tube to properly seat primer or wads, while retaining safety feature in allowing tube to move should it meet with an abnormal obstruction.

Note: Most modern wads and powders require no wad pressure, only that the wad is seated on the powder.

Note: Spreading safety clamp slightly with screw driver blade inserted between clamp ends will allow the tube to be readily located at the desired position.

STATION #4 Crimp Station.

It is important to crimp all shells with same crimp as they were originally crimped with either 6 point or 8 point. The crimp starter may be adjusted up or down by loosening the Nut #8476, Photo #35, under the turret is another nut which may be turned either up or down to give more or less crimp start. If you are processing paper shells, a smooth cone crimp starter is available which will do the best job.

Remember — giving more or less of a crimp start will often improve a final crimp.

STATION #5 Crimp Close

Cam is properly adjusted to give best overall results on all varieties of $2\frac{3}{4}$ inch shells. To obtain best possible crimps on certain types of cases, it may be necessary to adjust the cam slightly.

To Adjust: If crimp is not centered, or if crimp has a spiral configuration, loosen Cam Adjusting Lock Screw (A) and rotate cam in direction of arrow. If opening at the center of crimp is evident, rotate cam in opposite direction.

NOTE: When adjusting, move cam only a fraction of an inch at a time, testing frequently. A $\frac{1}{32}$ inch move may be sufficient.

To increase depth of crimp, loosen locknut (B) and screw crimping punch (C) down. Photo #36.

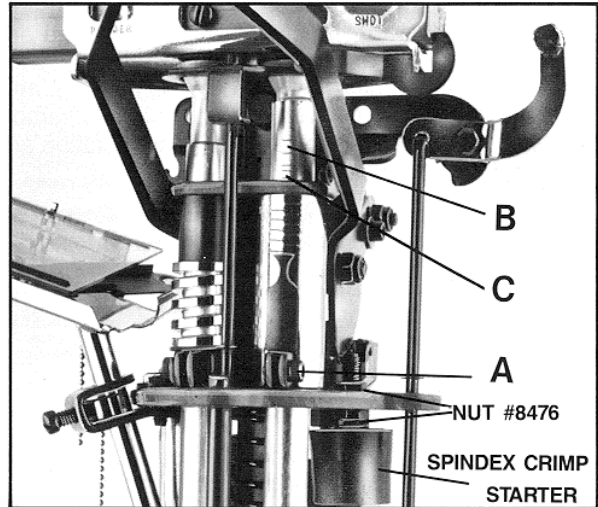

Photo No. 35

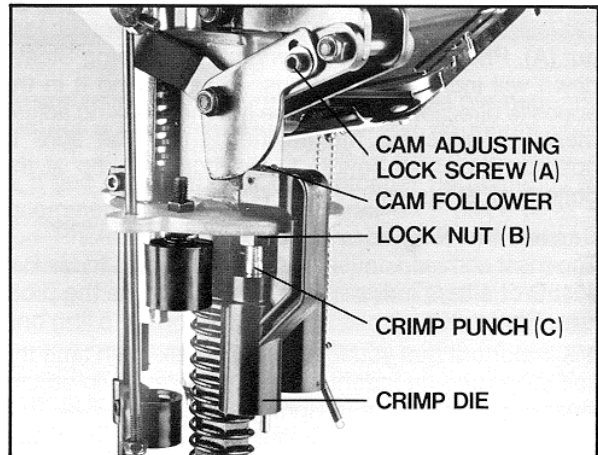

Photo No. 36

ADJUSTMENTS

As your loader comes from the factory the adjustment should be correct for most shells. There are two adjustments that can be made in the final crimp station. They are the cam adjustment Photo #36, Page 11, and the punch adjustment Photo #36. Four of the common problems which can be corrected by crimp station adjustments. Photos #37-40.

Shell #1 — crimp punch not deep enough. Correct by loosening lock nut #461A and turn punch deeper.

Shell #2 — crimp punch too deep. Correct by loosening lock nut #461A and raise crimp punch.

Shell #3 — opening in center of shell. Correct by loosening cam adjustment bolt and moving cam down about $\frac{1}{32}$ of an inch and try again.

Shell #4 — Shell has a swirl in the crimp. Adjust by loosening cam adjust screw and move the cam up or clockwise. Move about $\frac{1}{32}$ and try again.

Station #6 Final Crimp

Die is completely adjustable for radius. Loosening lock nut (A), Photo #41, and screwing the Crimping Sleeve down will increase the radius, while moving it in the opposite direction will decrease it. When making adjustments or checking the finished shells, be sure to operate the press handle to the positive stop at the bottom of its stroke.

Carrier Will Not Index Properly.

The most common cause for this is losing the Index Ball #515D or a bent index spring can also cause the problem, Photo #43.

It is important that you feel a crisp index each time the ball drops into an indent. This is adjustable. To adjust, merely turn the Column Spring #612, Photo #44. Putting the free end of the spring right at the index ball gives the highest pressure, Photo #44. The maximum pressure is usually too much for good indexing and primer dropping. Having the free end of the spring about 90° from the index ball is usually about correct.

Using Large Lead Shot.

Your model 650 was designed as a high production machine. Our charge bars with the soft insert allow you to reload with virtually any shot size up to BB. To prevent the lodging of large lead shot in the rammer tube, we recommend the use of our steel shot, large lead shot Adaptor Kit #8581-12. This is available in 12 ga. ONLY.

Charge Bar Will Not Release and Drop Shot or Powder.

This is almost always caused by the reprime tube not being adjusted low enough. It is necessary for the Clamp No. 507, Photo #20, to raise off the turret about $\frac{3}{16}$ of an inch. Refer to adjustment, for Station #2, Page 11.

Another cause can be the measure not being tipped all the way down. Pull the measure down solidly and make sure the pivot screw is tight enough to keep it there.

Charge Bar will not lock without shell in Station #2 (keeps charging shot and powder with no shells in the machine).

Check to see that the bar stop Screw No. 303, is touching the left side of the slot, that it travels in with, the handle down. If not, check for a bent bar actuator

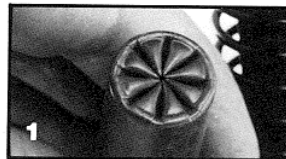

Photo No. 37

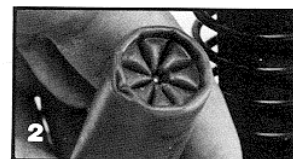

Photo No. 38

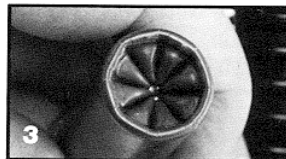

Photo No. 39

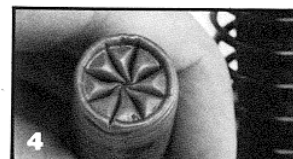

Photo No. 40

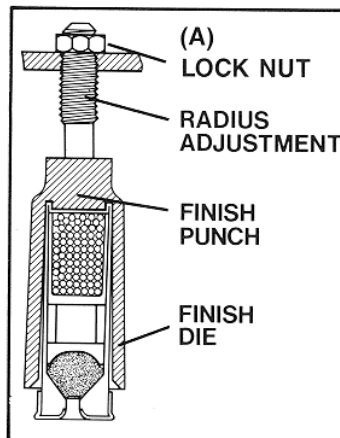

Photo No. 41

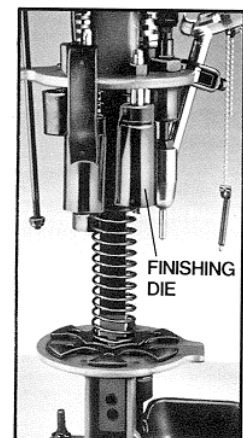

Photo No. 42

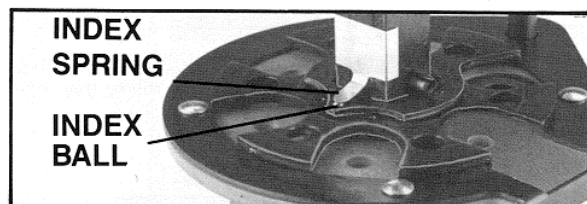

Photo No. 43

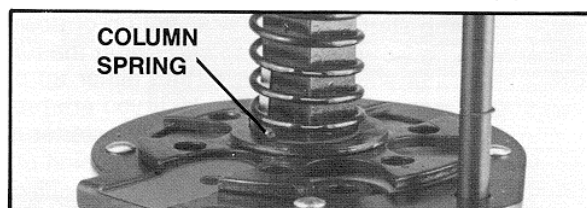

Photo No. 44

No. 8054. It can usually be adjusted by turning Nut #304J, Photo #45, to shorten the rod.

Check the spring and Bar Lock #670A, Photo #45. When pushing the bar to the left, the spring should snap the lock up and keep the bar from moving to the right.

Inaccurate Powder or Shot Charges.

Almost always caused by short travel of the charge bar. With a full carrier when the handle is depressed; the bar stop screw must travel to the full left side of the slot. If it fails to; turn adjustment nut up on operating rod #8055, so that the screw just hits the left side of slot when handle reaches bottom of stroke.

Note: It is always recommended that powder and shot charges be checked with a reliable scale. When checking these charges, do it during the normal operation of the machine.

ADJUSTMENT OF AUTO-CYCLE

While this unit was adjusted when the actuating rod was assembled, it may be necessary to readjust due to severe handling during shipment. To check, hold press handle at bottom stop position. The charge bar should now be all the way to the left. If charge bar is not as far left as it will go, use adjusting nut (A). Bar and handle must be synchronized so that the charge bar will hit left hand stop as handle hits bottom on down stroke position. It is best to check this with shot/powder containers removed.

Auto-Cycle is activated by the compression of the reprime spring at the time the primer is being seated. The measure assembly must be in an upright and level loading position, the charge bar positioned to the left as illustrated in Photo #45, with the carrier empty, the handle can be depressed and the bar will remain locked to the left position. With the handle depressed, the trip rod bracket will engage the larger diameter at the end of the trip rod, maintaining the compression of the trip spring. Upon inserting a shell in the carrier and moving it to the reprime station and depressing the handle, the spring compresses and the trip rod bracket no longer engages the larger diameter at the lower end of the trip rod. This relationship no longer holds the compression of the trip spring, and its expansion causes the bar lock to drop down and upon raising the handle, the charge bar moves to the right to drop the powder.

Upon moving the shell to the wad ramming station without the shell at the reprime station, the trip spring is again compressed by engagement of the trip rod bracket with the large diameter at the lower end of the trip rod and the lock spring, lifts the bar lock, to again maintain the position illustrated.

The full travel of the charge bar is required to permit pivoting the bar lock. The travel of the charge bar is controlled by the adjusting nut A, and it should be positioned as described in the first paragraph. It is mandatory that the measure assembly be upright and level and that the reprime spring, compresses a minimum of $\frac{3}{16}$ inch when a shell is in position to receive the powder charge. To position the bar for autocycling, the bar must be moved to the left either manually or by depressing the handle to allow the bar lock to hold the bar in the extreme left position.

For convenience, factory setting of the reprime tube allows priming of both high and low base shells but it is suggested that the tube be positioned for each type of shell. Activation of autocycle requires that the reprime spring be compressed approximately $\frac{3}{16}$ inch, which has been determined as sufficient to seat the primer and keeps the effort required for operation at a minimum.

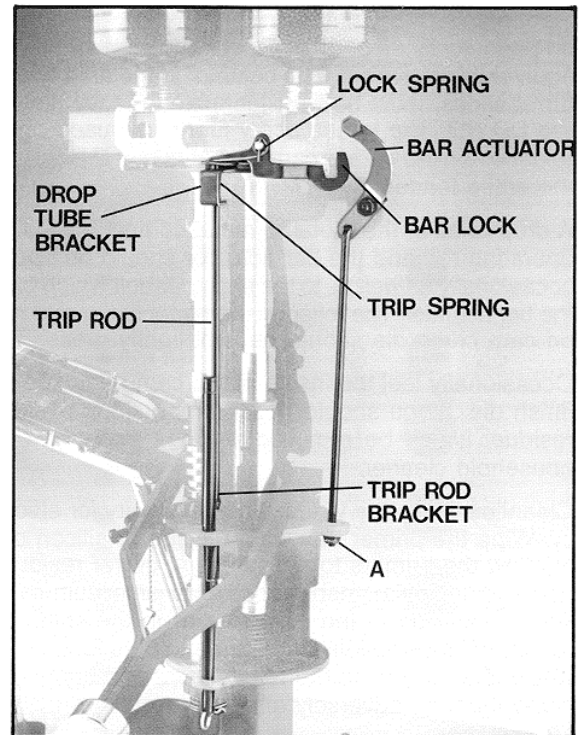

Photo No. 45

LUBRICATION/CARE

Pivot points (1-2-3) of the scissor linkage are to be oiled periodically on both sides, our choice is EP90 or its equivalent (heavy oil). The column, in the area that the turret slides, must be kept lubricated (heavy oil "A"). We *DO NOT* like to see spray lubricants used on the reloader. These sprays cause a buildup of residue over the entire loader.

A drop of oil at the metal to metal contact area of the operating rod and the bar actuator should be applied occasionally as well as to the shoulder bolt which pivots the bar actuator. The roller on the bar actuator and roller on cam crimp die should be kept lightly greased.

Occasionally feel the inside of the cam crimp die and finish die. If you should notice any buildup of dirt or residue, it can be removed using a swab with any household cleaner.

Cleanliness is not a virtue, it's a necessity for efficiency. Wipe the primer tray with a tissue or silicon cloth to allow the primers to slide freely. Powder residue is abrasive and inflammable, don't allow an accumulation. Shot should be in the container or in the shell. The results of loose pellets found under a bare foot, in your wife's shag rug or in the reloader mechanism will, in some manner, adversely affect your efforts.

A little care for a lot of service.

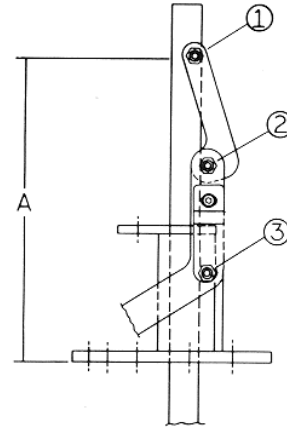

IF YOU HAVE TROUBLE

Oversize shells

A shell that goes into your gun hard but comes out easy is caused by oversize plastic or paper.

In the case of plastic shells, overfilling is almost always the cause. To correct you need:

1. A case with more capacity
2. A shorter wad
3. Less shot
4. A more dense powder
5. Sometimes using more wad pressure will give more room in the case

Over or under filling is most often corrected by using the proper size wad.

If using paper shells, any of the above can be the cause but the most common cause with paper shells is to swell up by absorbing moisture. The only way to remedy this is to dry the cases before reloading. **Never attempt to dry loaded cases.** Putting them in the oven at about 200° for 30 minutes will usually dry them. Don't even attempt to load paper cases during hot humid weather.

Case bulges above the brass:

When a case bulges above the brass, it is usually caused by overfilling the case. To correct:

1. Use a case with more capacity
2. Use a shorter wad
3. Use less shot
4. Use a denser powder
5. Use more wad pressure (40 lb. is usually sufficient).

Can also be caused by cam adjustment or punch adjustment being too low.

Poor Crimps

1. Hole in crimp
Refer to punch and cam adjustment
2. Misfolded crimps
Using wrong crimp starter 6 to 8 point
3. Swirl in crimp
Caused by cam adjusted down too far, refer to cam adjustment.

Shells that will not go into the magazine tube on a pump or automatic are caused by:

1. Excessive resizing. Resizing shells often that have been fired in a gun with a large chamber tends to push material into the rim of the shell causing it to be oversize.
2. Adjusting the resize ring down to where it flattens the rim of the shell will cause the rim to be oversize.

Powder Leaks From Measure

Usually caused by not having brass washer in place when using Winchester Powder. Install per instructions at Photo #3, Page #5, Section N.

This washer is placed under the grommet with the smooth side down.

MEC Charging Bar — A complete assortment of "quick-change" charging bars is available for any load or gauge. See charging bar chart packed with each loader or write to MEC for a complete list of bars. List also recommends proper bar for any combination of shot and powder.

CAUTION: Only dry lubricant, such as powdered graphite is to be used on the charge bar slide or at any point where lubricant may contact powder.

