

Shotshell reloading with the MEC SUPER 600

The Super 600 performs up to 12 operations on 6 individual shells simultaneously with one stroke of the press handle. It also features the revolutionary Star Crimp Head, Automatic Primer Feed, exclusive Resize-Deprime apparatus, Toggle Linkage, and Cam Operated Crimping Die. These Mec reloaders come completely assembled, tested and ready to use... without adjustment. With these many features and a low price they are easily the finest reloaders on the market.



LET'S START LOADING

Your Model Super 600 is completely assembled and tested at the factory, and is ready to provide long trouble-free service. Just follow these simple instructions.

UNPACKING

Examine the contents of the shipping carton for damage or shortage. In addition to the assembled loader, the carton will contain 2 shot and powder containers with caps, three 1/4-20 machine screws and wing nuts for mounting, primer catcher, resizing ring with support tube and resizing adaptor plate, and primer seating assembly which is taped together. Immediately report any shortages or damages to your dealer or delivering carrier.

MOUNTING

Place unit in desired position on bench and mark base mounting holes. Drill at marks using a 9/32 bit and then secure press to bench or mounting base using screws and wing nuts supplied. Note that bench is desirable but not required. Press can be fastened to wood or metal base and be completely portable. A very nice mounting base can be made from 3/4 inch plywood approximately 12" wide and 18" long with the press being mounted somewhat back of the center on the 18" length. Before screwing shot and powder containers into place, be sure neoprene grommets are in place in the measuring assembly.

AUTO-CHARGE MECHANISM

Your MEC Super 600 is equipped with the exclusive Auto-Charge Bar mechanism. This mechanism in no way affects the flexibility of the flip-type measure. Powder, shot or charge bar can be changed as easily as with any other MEC model.

ADJUSTMENT

While the unit was adjusted before the actuating rod was assembled, it may be necessary to readjust because of severe handling during shipment. To check, hold press handle at bottom stop position. Charge bar should now be all the way to the left. If charge bar is not as far left as it will go, use adjusting nut (A). Bar and handle must be synchronized so that charge bar will hit left hand stop as handle hits bottom on down position. It is best to check this with machine empty.

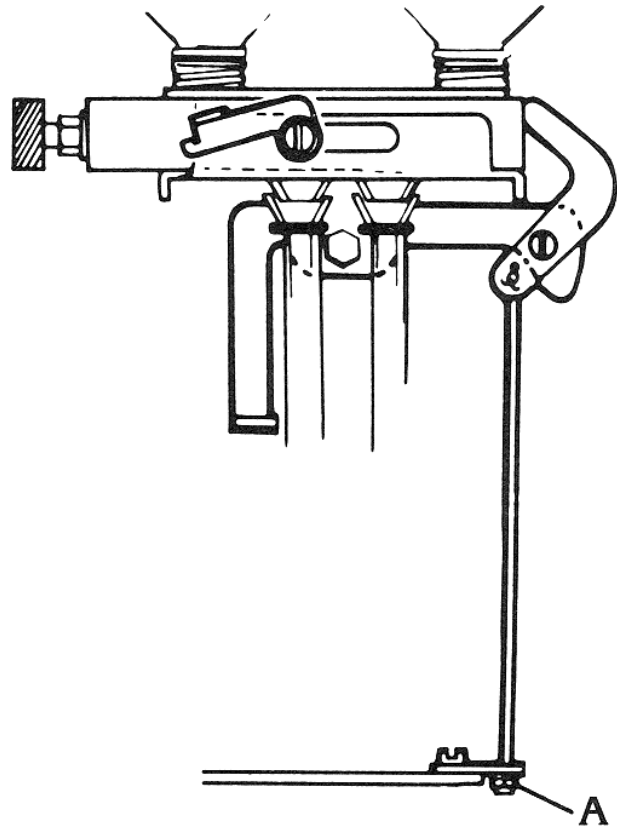

Let's Take A Look At The Super 600

Before you actually try reloading, it might be well to look over your loader, comparing it with the photograph at the right which identifies all the parts and dies you'll be using.

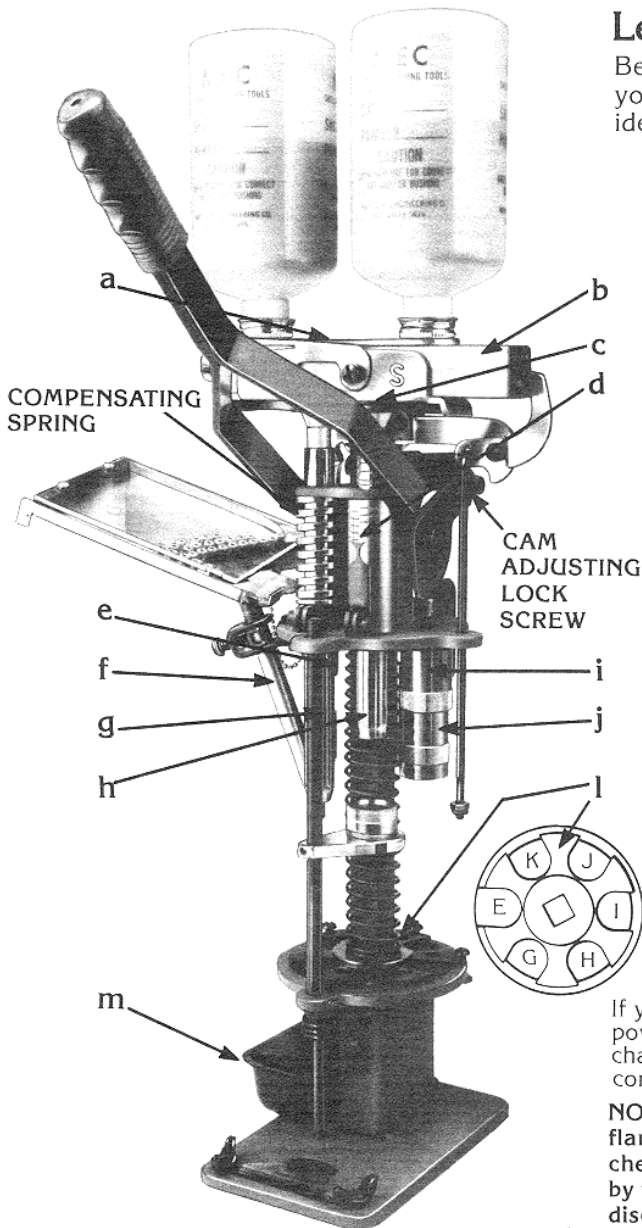

- a Note that the MEASURING ASSEMBLY pivots back for easy charging or changing of loads. This assembly is hinged by a machine screw with wing nut, which should be tightened to a point where some drag or resistance is felt when the measure is pivoted.
- b The CHARGING BAR is located just under the powder and shot containers. Each stroke of the press handle automatically moves the charge bar to left and right, measuring and dropping precise amounts of powder and shot into the shells. Bar can be operated manually if desired, by removing actuating rod.
- c SAFETY TUBE CLAMPS which will prevent primer detonation in case of obstruction. (Rammer tubes will slip under excess pressure.)
- d WAD PRESSURE INDICATOR gives exact amount of pressure actually being applied to wad column at bottom of handle stroke. See explanation on page 6.
- e DEPRIMING STATION at which the shell opening is ironed, and may be resized for diameter and head spacing if necessary.
- f AUTOMATIC PRIMER FEED positions primers in shell carrier with each stroke of the handle.
- g REPRIMING STATION at which shell is also charged with powder. Spring applies proper amount of pressure and in addition compensates for variations in height of base wad.
- h WAD RAMMING STATION at which shot is also charged thru the wad ramming tube. Mechanitrol Wad Guide positions itself on shell automatically allowing any practical wad column to be seated with one stroke.
- i CRIMP STARTING STATION.
- j CRIMPING STATION containing the exclusive cam-operated two-stage crimping apparatus. Die is completely adjustable for depth of crimp.
- k RESIZING AND FINISHING STATION. Radius may be adjusted to suit individual taste.
- l SHELL CARRIER into which shells are placed and which automatically position each shell at the proper station.
- m PRIMER CATCHER which is secured into position by tilting so that notched edge slips under the tab provided in the base.

If you haven't already talked to your dealer about the different kinds of powder, shot, primer and wads, please refer to the information on the charging bar chart packed with each loader. This chart lists the various combinations of powder, shot and wad columns.

NOTE: Common sense precautions are advised, careless handling of flammables and explosives can result in serious injury. We endorse checking charges with a reliable scale, adhering to loads recommended by the powder manufacturer and suggest the use of safety glasses. We disclaim any liability for damage or injury resulting from reloading shot shells.

PRIMER SEATING ASSEMBLY

Your Super 600 is equipped with the exclusive self-cleaning primer seating assembly. It consists of 3 parts. Spring pad (A), seating spring (B) and seating arm (C).

To Install: Hold spring pad in place on underside of base with left hand. Place spring on seating arm and insert into pad using upward pressure. Seat pointed base of seating arm in detent provided for this purpose.

To Remove: Simply grasp seating arm, lift and pull toward you.

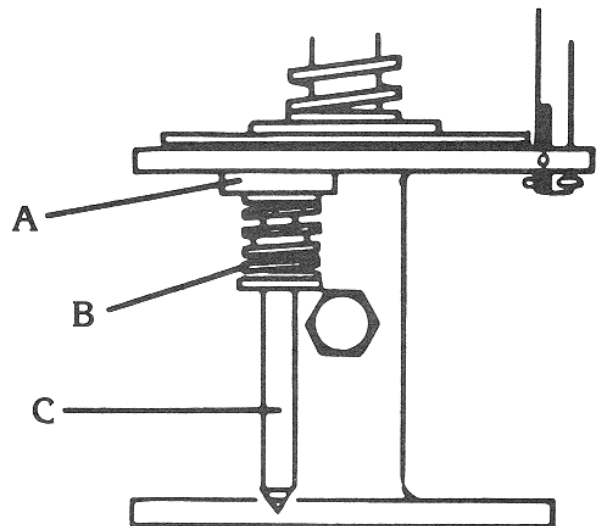

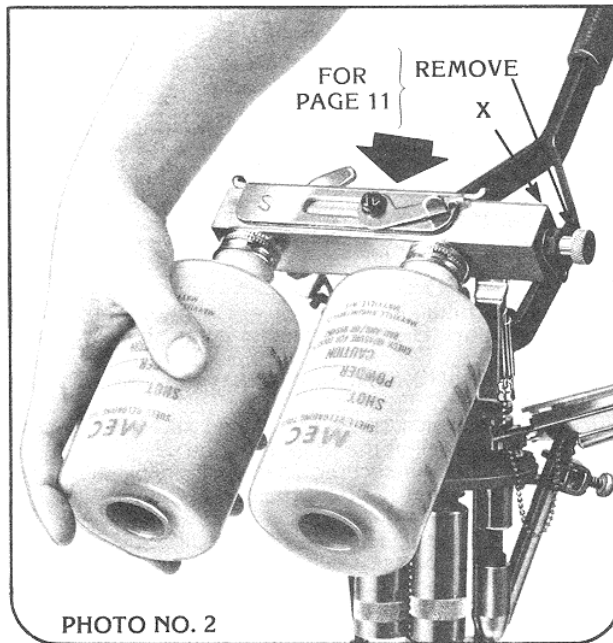
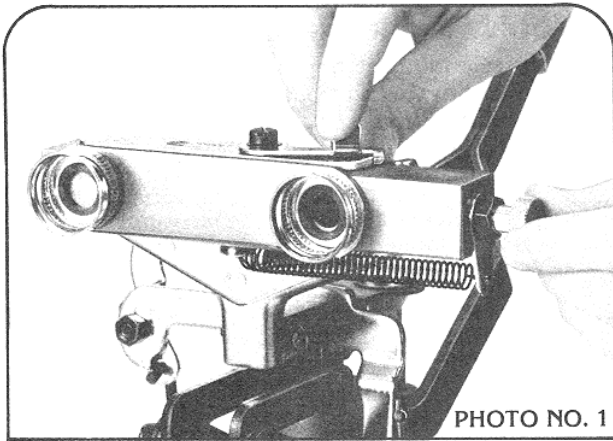

CHARGING

CHECK FOR CORRECT BAR &/or BUSHING! As a precautionary measure, powder opening in optional, bushing type bar is closed with a disc. Remove charge bar, discard disc and insert proper bushing. CHECK AGAIN and continue.

Release charging assembly wing nut and flip or pivot containers down to charging position. Pull the charging bar to the left as far as it will go, and lock in this position using locking lever (see photo No. 1). Fill container with powder and shot. Replace containers, powder container first, making sure it is mounted in the proper position (position P for powder and S for shot). Next replace the shot container. (Note: Use only light or moderate pressure when tightening containers). Because of the weight factor, support the shot container with your hand while in the charging position so that there is no danger of its tearing loose under pressure (see photo No. 2). While still supporting the shot container with your hand, flip the assembly to the upright or loading position.

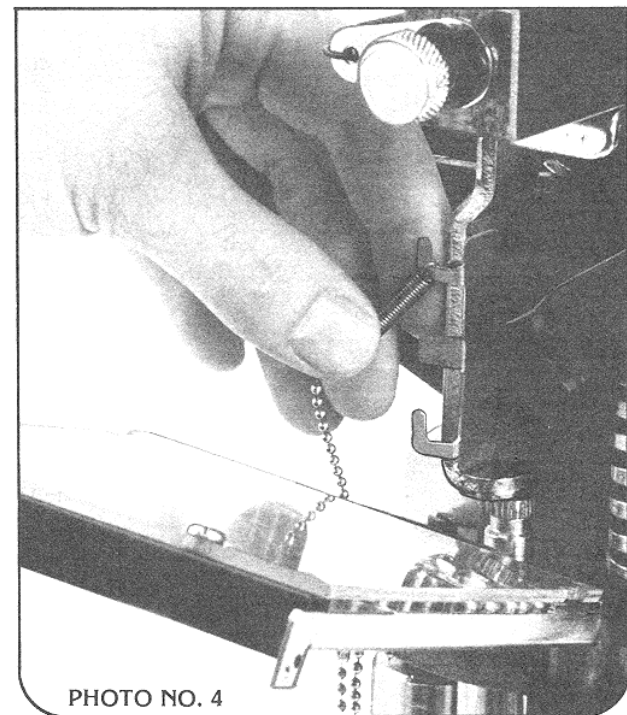
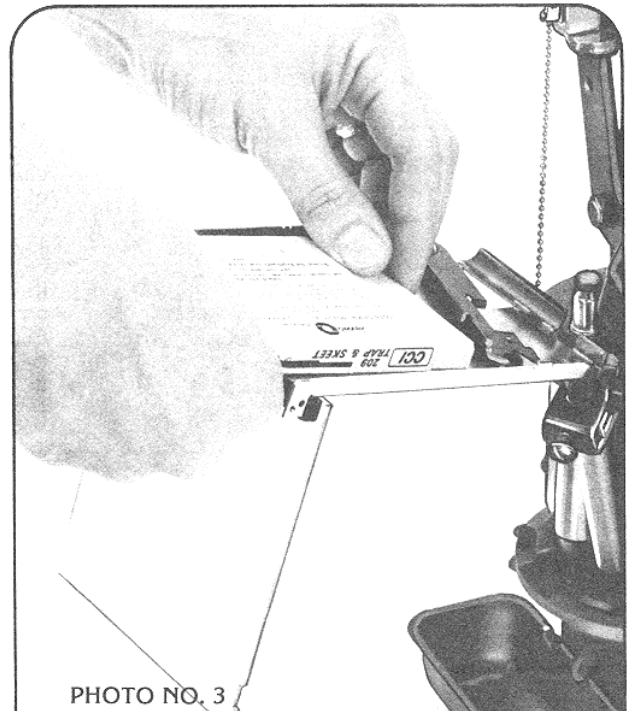

PRIMER FEED

Open cover, position primer box face down on tray. Slide cover from right to left, leaving liner and primers. Carefully lift liner, allowing primers to remain on tray, close cover.

To interrupt the flow of primers, detach spring from upper projection on spring keeper, store on lower projection. Attach spring to upper projection to resume feed.

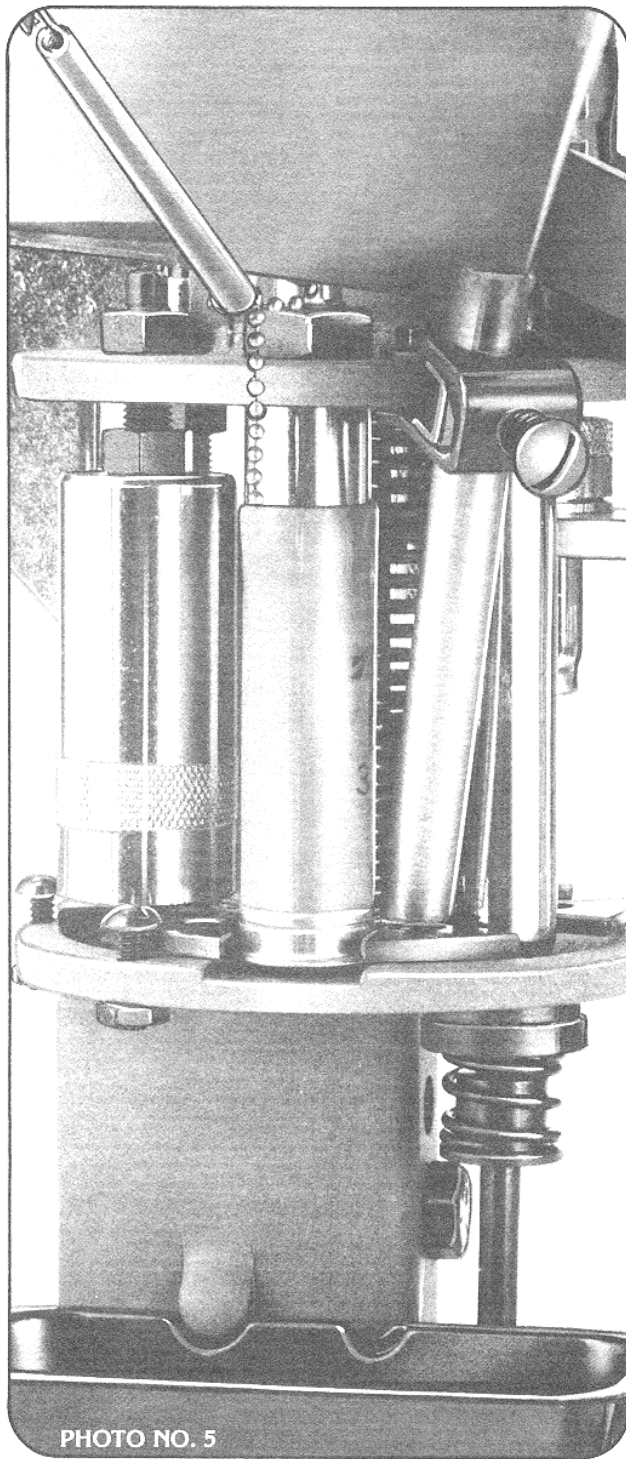

STEP ONE

Place shell into carrier at depriming station and depress handle (see photo No. 5). This operation deprimes the shell and drops primer into shell carrier aperture. Now rotate carrier counter-clockwise.

Note: Rotation is a two-stage motion, with click stop positioning, which drops primer into seating assembly and then positions first shell under reprime tube.

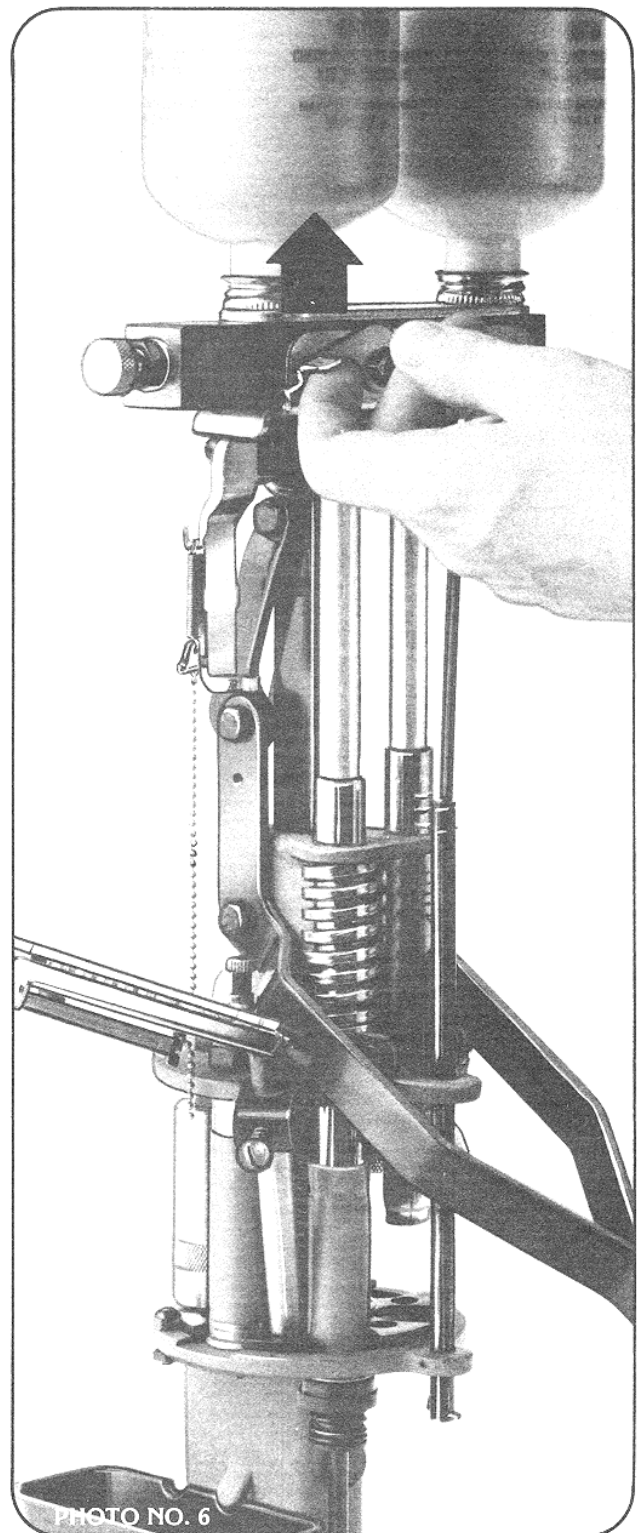

STEP TWO

Again place empty shell into position and depress handle. Now while the handle is in the down position, release the charge bar locking lever (see photo No. 6). This operation now reprimed and charges powder as well as deprimes the second shell. Again move carrier counter-clockwise to the next station.

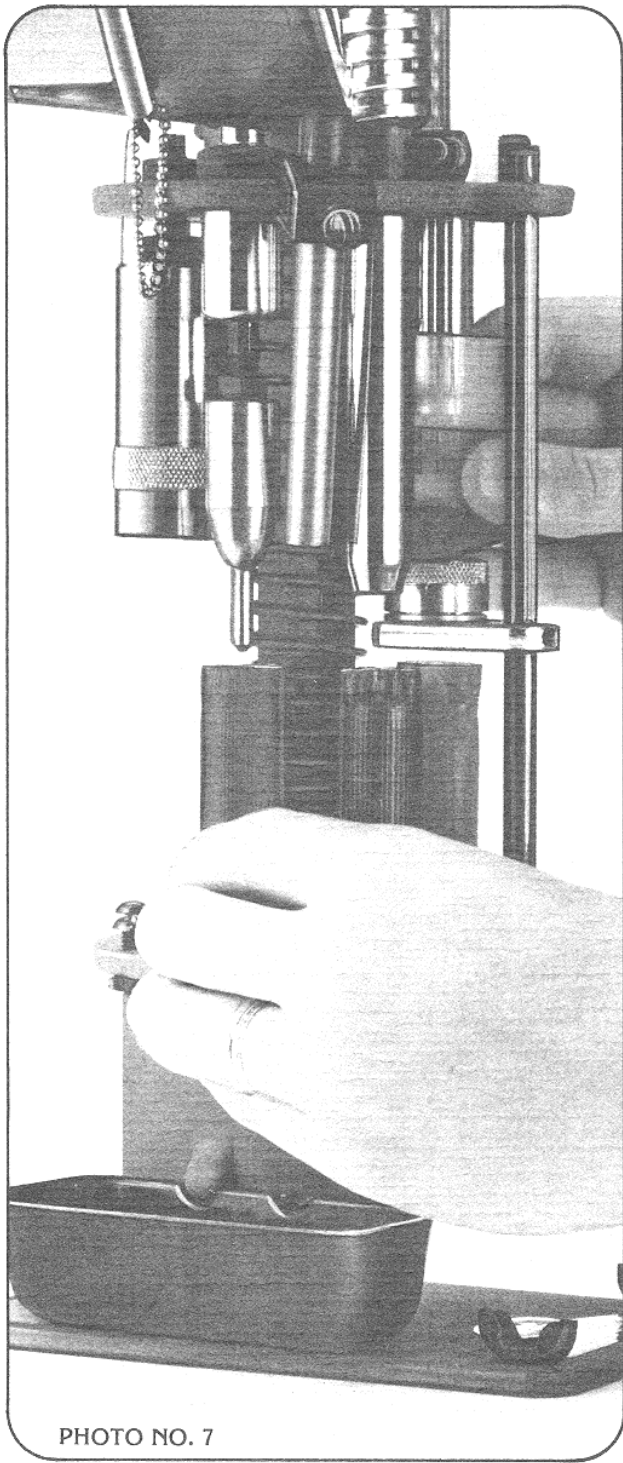

STEP THREE

Place proper wad column in wad guide and empty shell into carrier and again depress handle (see photo No. 7). Important: Do not force wads into guide as this spreads the fingers, preventing the wad guide from dropping into position on the shell. This operation deprimes, reprimed charges powder, seats wads and charges shot. Continue this same sequence of operation from this point on. Wad pressure can be checked while handle is depressed.

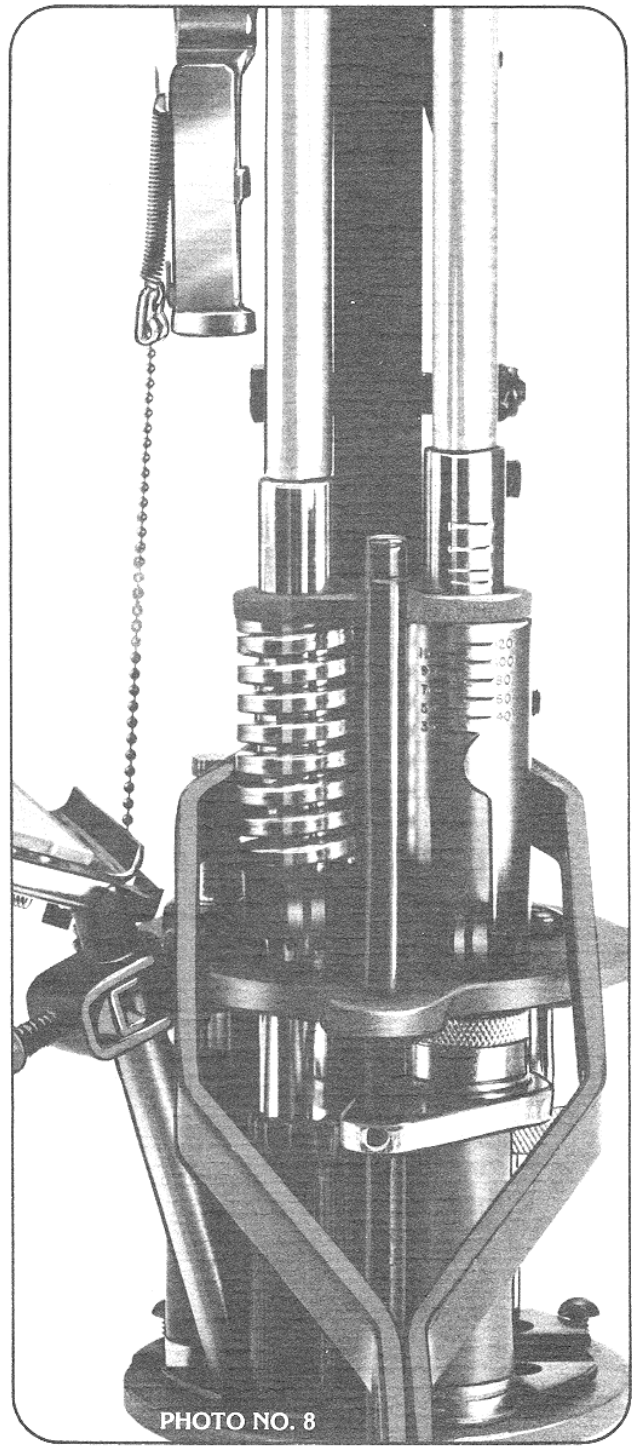

While visual checking is not necessary, pointer indicates the exact amount of pressure being applied to wad column when handle is depressed. Reading is always positive regardless of any other adjustments. While tool has been pre-set at the factory for average pressure required, you may find it desirable to increase or decrease pressure. This is done as described on page 11.

Note: Factory setting is recommended for all modern wads.

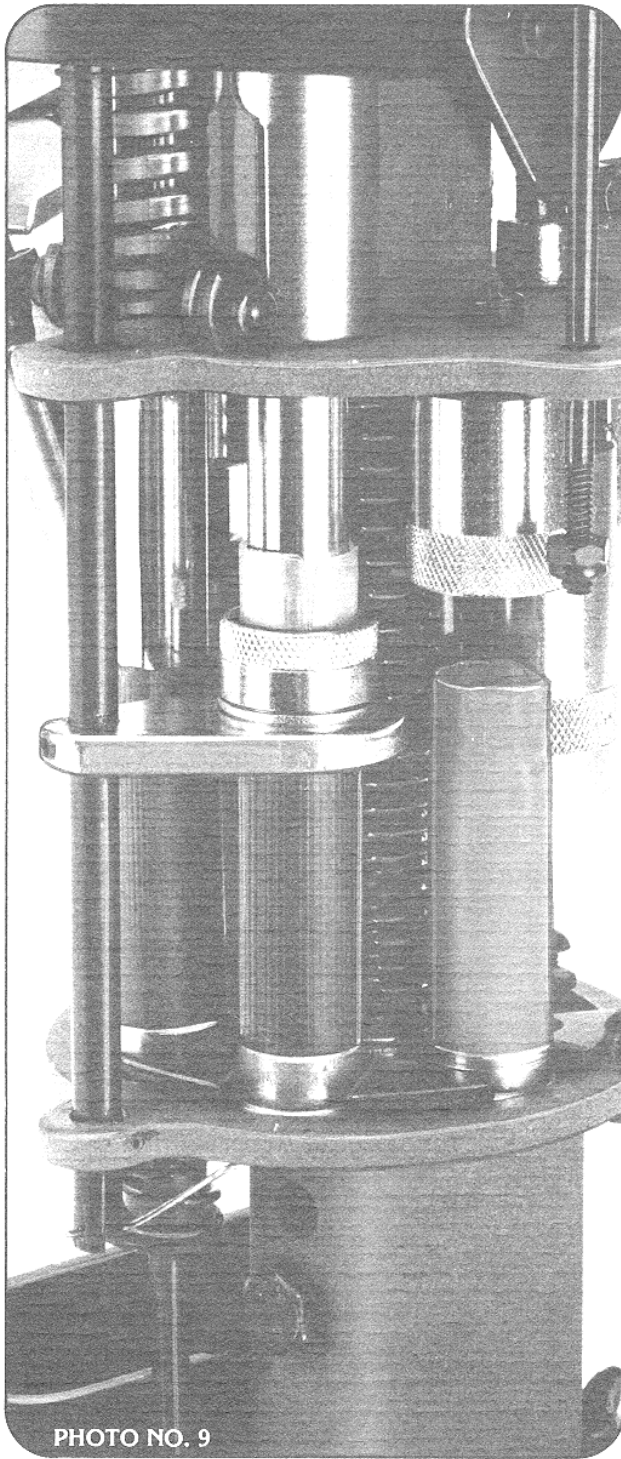

PHOTO NO. 9

STEP FOUR

The Spindex Star Crimp Head with 8 point spinner and 6 point insert is standard. This 6 point insert is preferred for all new paper cases and some plastics. To obtain best quality crimps it may be necessary to index some types of shells so that folds return to original positions (see photo No. 9). When loading previously fired paper cases and some plastics, we suggest our part 634 P insert (optional) to start the crimp.

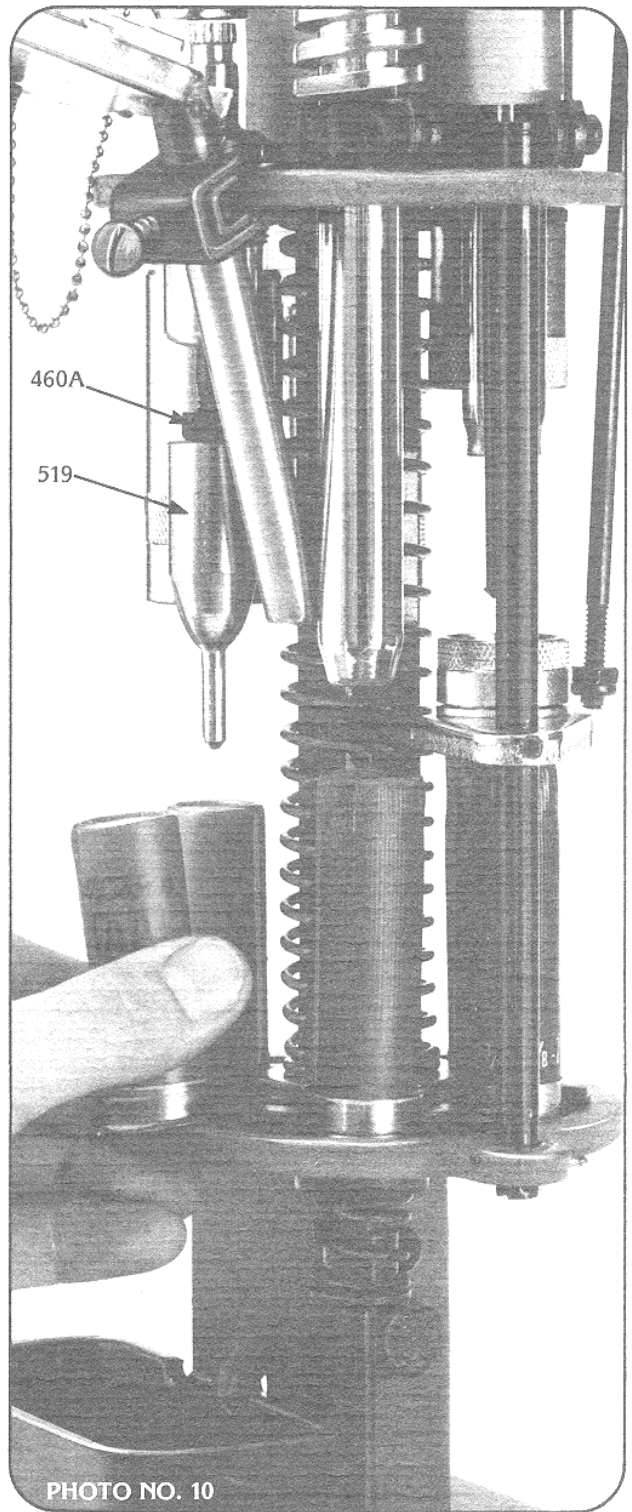
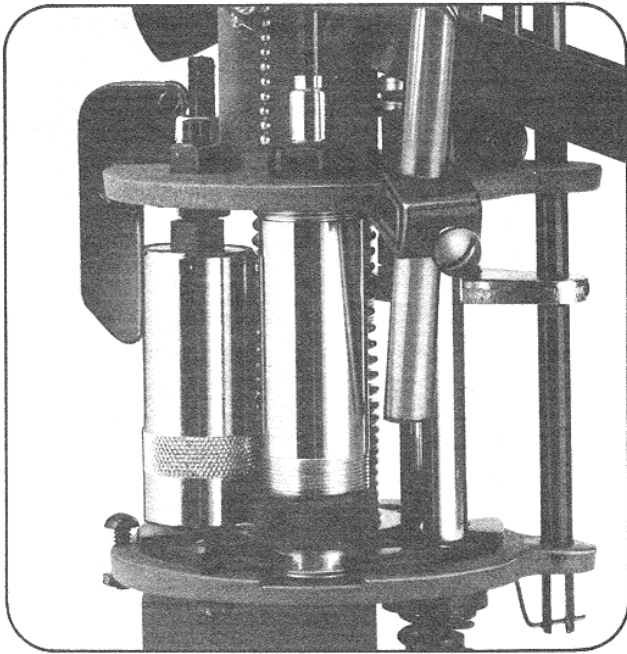

PHOTO NO. 10

STEP FIVE

When carrier becomes full it is indexed by grasping the loaded shell and pulling it forward to the "gate" aperture at the depriming station (see photo No. 10). Perform the operations slowly at first, making certain that all hand movements are done exactly as shown throughout. Increase speed slowly, only after you have the technique firmly in your grasp.



IF YOU HAVE TO RESIZE

Cases which do not slip readily into shell carrier should be rejected, to be resized to the proper diameter and head spacing after a considerable number have been accumulated. To resize at that time, lift primer feed remove shot and powder containers. Screw resizing ring and support tube into position over depriming punch. Now slip resizing adapter into carrier below. Next slip the empty case into resizing ring and depress handle. This will bring metal portion of shell to original dimension. Apply force to handle in upward direction to eject shell from ring. In some instances, adjustment of the deprime punch may be required to obtain the strike required to strip the resize ring from the shell. With support tube removed, loosen locknut, 460A, turn deprime punch, 519, down to gain additional stroke. Return punch to clear shell prior to reloading. (SEE CALLOUTS, PAGE 7). If a great number of cases are to be resized, the MEC Case Conditioner is recommended.

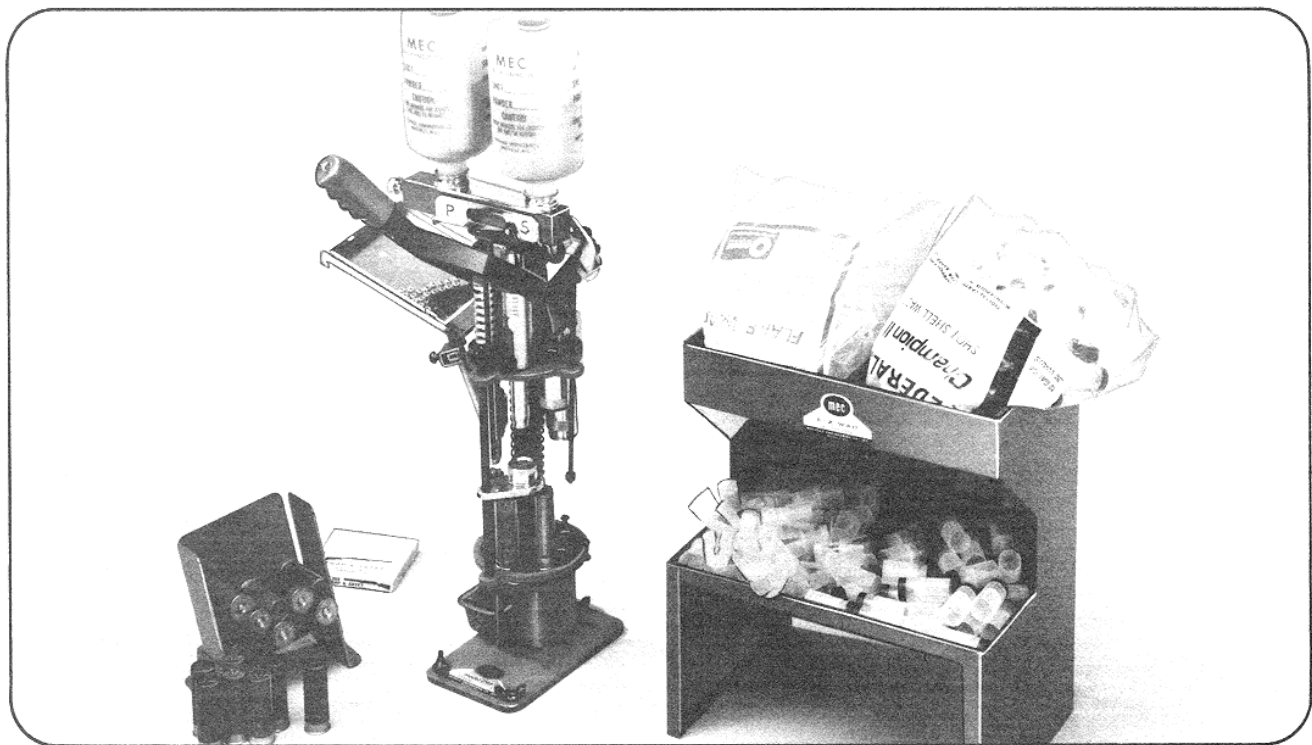

SPEED

In order to obtain maximum production speed it will be necessary to arrange components properly. Empty cases should be positioned to the left of the tool. A box or the MEC E-Z PAK should also be placed on this side. Wads should be positioned to the right. If paper components are to be used and you don't have the MEC E-Z Wad Dispenser, stacking the wads before starting actual reloading operations will also help to obtain increased speed of operation.

OPERATING MANUALLY

Under some conditions, such as when abrasive powder or heavy shot is to be used, it may be desirable to operate charge bar manually. To do this, remove bar lock and return spring, pull cotter (D) and remove actuating rod (A). See page 2.

TIPS ON MODEL SUPER 600 OPERATION

The Model Super 600 is the simplest and speediest of the progressive type tools. While it is actually more simple to operate than the single stage type presses which operate one shell at a time, more attention must be paid to detail, since the misloading of one shell may affect the characteristics of all the shells in the press at that time.

It is best, therefore, to segregate your shells as to make and type and to remove from your bench all but the components to be used in the particular type shell being loaded. This will eliminate the possibility of accidentally using the wrong size primer or the wrong size wad, etc.

If you must develop your wad column, you may find that passing a single shell through the various stages will be helpful.

APPROX 9/16" WADDING

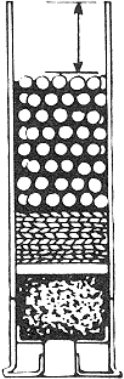

While wadding is primarily concerned with the sealing and cushioning of the rapidly expanding gases given off by the explosion of powder, an important secondary function is performed. It is in connection with the volumetric capacity of the empty shell itself and that of the powder and shot charge used.

Very simply, the quality of the crimp on the finished shell is very much affected by the space taken up by the components column. A rule of thumb relating to this calls for a difference between the level of the shotcharge and the mouth of the open shell. The dimension should be approximately 1/2 inch for 12 gauge plastic shells (9/16 inch for paper shells). Use a dimension of 1/2 inch for 16 gauge, 7/16 inch for 20 gauge, 3/8 inch for 28 gauge, and 5/16 inch for .410 bore paper shells. Reduce approximately 1/16 inch for plastic shells. REMEMBER that this is an approximate dimension which may have to be adjusted slightly to suit the method of crimping used on your particular reloader.

In the beginning, PICK UP ALL OF THE COMPONENTS USED TO MAKE THE FINISHED SHELL AT ONE TIME, the empty shell in the left hand and the correct wad column in the right hand, and then place them all into the press at one time, making sure that the handle is not operated until your hands are empty. This will eliminate any possibility of forgetting to include one or more components.

Be careful in making adjustments. Your MEC loader has been carefully tested and adjusted at the factory and is set to produce the standard 2-3/4 or 3 dram target load, using either high or low base type target shells. If only high base wad shells are to be processed, it may be preferable to adjust the reprime tube of your loader. Position the tube to seat the primer properly with the least amount of spring compression. Too low will cause the press to fail to close

completely and result in faulty depriming and crimping or in squashing the base wad which may obstruct the flashhole and cause faulty ignition. Too high will fail to seat the primer.

In making adjustment, bear in mind that each station depends upon the others and an adjustment at one station may affect the operation of one or more of the others. IMPROPER ADJUSTMENT AT ANY STATION MAY MAKE THE UNIT COMPLETELY INOPERATIVE.

DEVELOPING THE WAD COLUMN

First, check the MEC bar chart. The wad columns given for the particular loads are reasonably close, but must be altered depending upon conditions which vary with the individual. Make and type of wad, wad pressure and condition of the hull are some of the variables. Load one shell at a time until you have developed a wad column which results in a desirable crimp.

LOADING ONE SHELL AT A TIME

- No. 1 Lock the charging bar to the left (See page 4).
- No. 2 Insert shell in gate (See page 5) and deprime.
- No. 3 Index shell to station G, page 3 and reprime. Release Bar Lock and powder will be charged on the upstroke of the handle (See page 5).
- No. 4 Index shell to station H, page 3 and seat wad column. Shot will be charged on downstroke. Lock charge bar to the left at completion of handle stroke.
- No. 5 Index shell to crimping station J, page 3 and crimp. (Use crimp starting station 1, page 3, if necessary).
- No. 6 Finish crimp and resize at station K, page 3 and remove shell. When a suitable shell is obtained, you may load carrier per instructions.

LOADING 3" SHELLS

To process 3" shells, remove cap screw at base of column. Pull column upward 1/4 inch and fasten, using top hole in base and top hole in column. Additional item required is the 460-10A spacer. This item, along with instructions for adjustment, is available upon request.

AVOID MISTAKES

Pick up everything you are going to use and put it into the unit at one time. If you do not operate the handle until you have emptied your hands, you will never make a mistake. To operate most efficiently, see page 6 and follow instructions given.

IF YOU HAVE TROUBLE...

...with oversize shells (paper)

1. You may be using too many wads. If the crimp bulges when the shell is finished, or if bulging or crushing of the paper adjacent to the brass base is evident, your wad column is too high. If the crimp tapers inward and has an opening in the center, the wad column is not high enough. In either case, correct your wad column so that the resultant crimp is tapered inward slightly. This will insure maximum locking in of the contents as the toggle action will cause the shell to withstand considerably more abuse without spilling shot.

2. The shells you are using may be moist. This is certain to cause trouble, and especially so, when oversize wads, or too much pressure, or a combination of both enter into your loading operations. Paper shells DO ABSORB MOISTURE, and their size is directly related to the moisture content of the paper. Hot weather, when high-humidity conditions are unnoticed, will give you your greatest trouble with oversize shells. Your cases may be as much as .015" larger than when working during the winter or during the season when your storage and working area is heated. Dehydrating your cases in the oven of your kitchen range at a temperature of approximately 200° will give surprisingly good results.

3. Check the wads you are using to be sure they are of the correct gauge. Oversize wads will exert too much side pressure on the wall of the shell, causing it to expand when ejected from the resizing die. The same condition results from too much pressure on the wad column. Whenever upward pressure is necessary to extract the shell from the crimping die, it may give trouble if your gun has an exceptionally small chamber. Soft cases will tend to swell slightly during storage, and this, too, could cause trouble. Immediately inspect any shell that requires excess extracting pressure. Remember, any shell that requires high extracting pressure has expanded much more than one that extracts easily.

4. The brass base of the shell may be oversize. This portion of the fired shell varies widely and is sometimes so large that it is impossible to resize by conventional methods. Because of the excessive pressure necessary to extract it from the crimping die, it is advisable to perform a preliminary operation on some domestic and foreign shells, using the special resizing apparatus that is shipped with each Press. The use of this equipment is fully explained on page 8.

...with longitudinal crease

This crease usually occurs in paper shells which are considerably oversize. Firing in a large chamber plus humid conditions tend to enlarge the problem. A quick resize does not allow time for the paper fibres to squeeze together and collapsing of the case results in the crease. Slowing the resizing operation improves results or may eliminate the crease entirely.

...with crimping die sticking

Remember, the results that you get from your Loader will, to a great extent, depend upon the condition of the crimping die. The bore of the die is made to exacting tolerances and should be protected between periods of operation. A light coating of oil is suggested as a rust and corrosion preventative. Be sure to remove all oil and check for possible rust and pitting before actual use.

1. Check your shells for moisture. If necessary, dry them as explained in part 2, above.
2. Check your shells for dirt or other foreign materials.
3. Check for oversize wads. To get good results you must use quality components.
4. Check for oversize brass. Resize as explained on page 8 if necessary.
5. Do not lubricate paper shells. This softens the paper and makes them difficult to resize. In addition, the finished shells will expand in storage.

IGNITION

Uniform ignition requires confinement of the powder. Loosely confined powder results in muzzle flash, a loud report, light recoil and little velocity. It is suggested that the wad exert some pressure on the powder after the crimp is formed. Shells having a composition base wad should be inspected after the primer is seated to be assured that the flash hole is unobstructed. Use primers of the appropriate size.

...with misfires or poor ignition

1. Check your powder and primers for moisture or dampness. Never expose the powder to air for any extended period. Most powders will absorb moisture from the air, especially under humid conditions. This will affect the burning characteristics as well as the weight. Whenever checking the weight of your charges, always use fresh powder from a sealed can and agitate to a certain extent to assure uniformity of mixture. Always check the weight of your charges during actual machine operation since movement of the machine will greatly affect the weight of the powder charge especially if it is of the fluffy or less dense variety. Be sure to store your primers in cool dry surroundings.

2. Check the bases of your shells for "dishing." If you find this condition, exert more pressure during the Repriming operation. This will flatten them. Poor detonation or misfire is often caused by the firing pin not striking the Primer with the proper impact due to this "dishing."

3. Be careful not to run out of powder or shot. Many cases of poor ignition or misfire are caused by the loading of several shells before noting that the powder container is empty. A light shot charge often produces muzzle flash or blast.

4. When you have misfire with the Primer showing evidence of good contact with the firing pin, you may have accidentally used a spent primer.

...with charging bar operation

1. Check condition of grommets. Jambing, shearing shot or excessive powder leakage is usually related to the condition of the grommets. If worn, remove and replace or reposition with worn spot in new position.

NOTE: Special neck dimensions of MEC containers were determined to hold grommets in position and contribute to accurate charges. Avoid substituting another type.

2. String or threads of shot bag material will cause the charge bar to bind and fail to return to charge powder.

3. Under some conditions, powder residue can build up, causing sluggish action. Generally an application of powdered graphite will be adequate, although removing and cleaning bar and slide may be required to assure positive action.

4. Return spring stretched or damaged.

...with wad feeding

Condition of the mouth and manufacturers tolerance in the length of fired shells may dictate that the Wad Guide be positioned slightly lower than factory assembly for ideal operation.

...with split cases

Case splitting is usually due to stuffing the wads into the wad guide. This practice spreads the fingers and prevents the wad guide from dropping into place on the case. Damaged fingers could produce the same result.

CAUTION: Too low will crush shell mouth, too high will result in turret plate striking wad guide when handle is depressed and can cause bent guide rod.

...wad guide fingers (part 453—specify gauge)

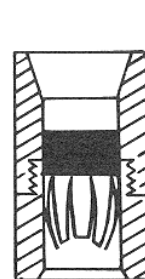

WAD holds flange in place for tightening.

The fingers are held in position by the cap screwed to the body of the wad guide.

TO REPLACE

1. Unscrew cap and discard damaged fingers.
2. Position replacement and tighten cap.

...WITH PRIMER FAILING TO SEAT

1. Wrong size primer.
2. Reprime tube not set properly. See page 2.

...PRIMER FEED, FAILURE TO FEED

1. If primers fail to drop, tighten chain in increments of one bead until satisfactory operation is obtained.

If primers drop too early and tend to tip in the openings of the carrier, loosen chain in increments of one bead to arrive at the proper adjustment.

2. Not centered over opening when handle is depressed.

...WITH CARRIER FAILING TO INDEX

1. Index spring, 615-C, broken.
2. Index pin, 515-D, lost.

3. Column spring may be rotated counter clockwise to increase, clockwise to decrease pressure on index pin, controlling degree of intensity of click stop indexing.

...primers fail to fall into seating assembly

see "NOTE" page 5, and preceding paragraph.

...unsatisfactory crimp

1. Improper adjustment of crimp die. See page 2 and 11.
2. Crimp starting head should be positioned to a depth that closes the shell to approximately one half of its open diameter. Starting folds too deep will scallop edge of crimp, too shallow may leave opening or may crush shell mouth upon crimping.
3. Build up or trapped foreign material in crimp dies will result in irregular crimp.

CRIMPING

Although not mandatory with some types, a star crimp head is desirable to return the crimp folds to their original locations, six or eight point, as the situation demands. On plastic shells, eight point closures predominate, although some are closed with six segments. Because of varying characteristics, the depth to which the folds are started will sometimes be reflected in the finish crimp.

The older SP cases, still available from dealer inventories, were unskived and required a friction or heat seal to close the opening at the center of the crimp. Upon firing the seal is torn away, and upon reloading, the area previously sealed appears as an opening. Thinning the mouth of the tube materially assists in reducing the size of the opening. A Bodkin arrow-head or plumber's reamer serves well as a chamfering or skiving tool.

Depending upon the condition of the case mouth, a crimp equal or superior to the original can be obtained by indexing the shell to form new folds exactly opposite of the original on previously heat sealed cases.

Some older compression formed cases will not satisfactorily accept standard size overpowder wads and it has been suggested that overpowder wads be one gauge smaller than the shell and that softer filler wads, such as Remington Mold Tite or Winchester Western molded fiber complete the wad column.

We suggest you avoid 3 inch 12-20-410 shells which were previously roll crimped.

...lubrication

All friction points are lubricated at assembly. Routine inspection should assure adequate lubrication of cam and cam follower at crimping station, bar actuator and point of contact on end of charge bar where a light grease is recommended. Machine oil is suggested for carrier, column, handle linkage, clamp screws and other friction points.

CAUTION: Only dry lubricant, such as powdered graphite is to be used on the charge bar slide or at any point where lubricant may contact powder.

TO ADJUST THE RESIZING AND FINISHING DIE

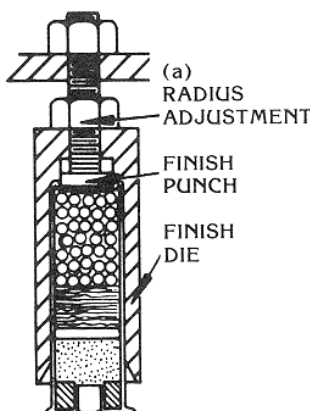

Die is completely adjustable for radius. Loosening lock screw (a) and screwing the Crimping Sleeve down will increase the radius, while moving it in the opposite direction will decrease it. When making adjustments or checking the finished shells, be sure to operate the press handle to the positive stop at the bottom of its stroke.

TO ADJUST THE RAMMER TUBE

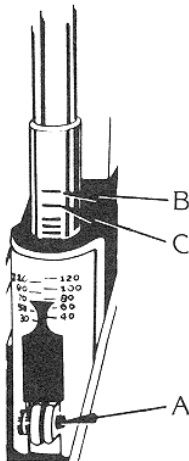

The MEC Rammer Tube is arranged to provide any wad pressure from 30 to 120 pounds. Using the hex wrench provided, loosen the safety clamp, "A." Set rammer tube to desired position (lower it to increase pressure — raise it to decrease) and tighten clamp. Indicator marks "B" and "C" should be used as a visual aid in making the adjustment. Check your setting by reading actual pressure on gauge face while applying pressure on correct wad column with machine handle in full lowered position. This will always be the actual pressure being applied to wad or wads. When tightening clamp, avoid overtightening. Moderate clamp pressure will hold tube to properly seat primer or wads, while retaining safety feature in allowing tube to move should it meet with an abnormal obstruction.

Note: Spreading safety clamp slightly with screw driver blade inserted between clamp ends will allow the tube to be readily located at the desired position.

TO ADJUST THE CAM OPERATED CRIMP DIE

Cam is properly adjusted to give best overall results on all varieties of 2-3/4 inch shells. To obtain best possible crimps on certain types of cases, it may be necessary to adjust the cam slightly.

To Adjust: If crimp is not centered, or if crimp has a spiral configuration, loosen Cam Adjusting Lock Screw (A) and rotate cam in direction of arrow. If opening at the center of crimp is evident, rotate cam in opposite direction.

NOTE: When adjusting, move cam only a fraction of an inch at a time, testing frequently. A 1/32 inch move may be sufficient.

To increase depth of crimp, loosen locknut (B) and screw crimping punch (C) down.

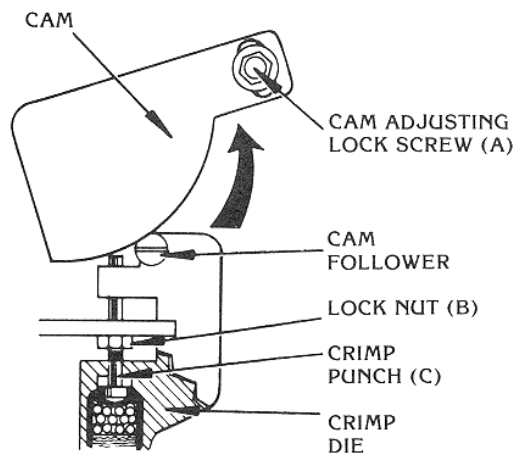

MEC Charging Bar — A complete assortment of "quick-change" charging bars is available for any load or gauge. See charging bar chart packed with each loader or write to MEC for a complete list of bars. List also recommends proper bar for any combination of shot and powder.

INSTRUCTIONS FOR REMOVING BAR.

Detach spring at "X," remove bar stop screw, slide bar out, replace with bar or bar and bushing of your choice. Replace bar stop screw and attach spring. See Photo No. 2, Page 4.

IMPORTANT: When ordering parts or accessory equipment, be sure to state make, model, and serial number of reloader on which they will be used, along with part numbers. See list packed with loader.

HYDRAMEC

650 and Super 600

A Minature Reloading Factory

Take the Super 600 or 650 reloader and marry it to a hydraulic system... the result is the hydraMEC, today's most advanced concept in high-volume reloaders. The hydraulic system is compact, lightweight and designed for long, troublefree service. The motor operates on regular 110 volt household current and the pump supplies instant, constant pressure... no slowdown, no misses. The entire downstroke and upstroke functions are utilized and synchronized to allow continuous action. Every stroke of the cylinder piston is positive and performs up to 12 operations on six reloading stations. Every downstroke of the reloader produces one finished shell. The operator inserts empty shells and wads... the hydraMEC does the rest... automatically.

ALSO AVAILABLE AS

HYDRAULIC UNIT ONLY — Hydraulic unit to include pump, motor, cylinder, controls, base, links and bolts required to attach to reloader with instructions.

OR

Tool linked for hydraulic operation to include base and cylinder. hydraMEC 650.

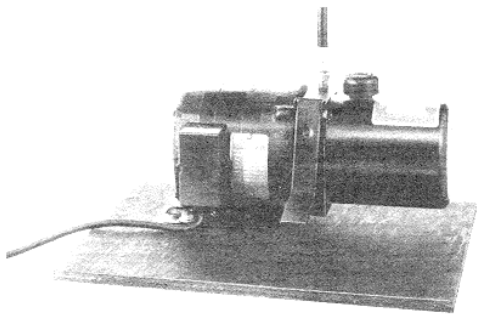

12, 16, 20, 28 and
.410 gauges — fitted
in beautiful lifetime
chrome

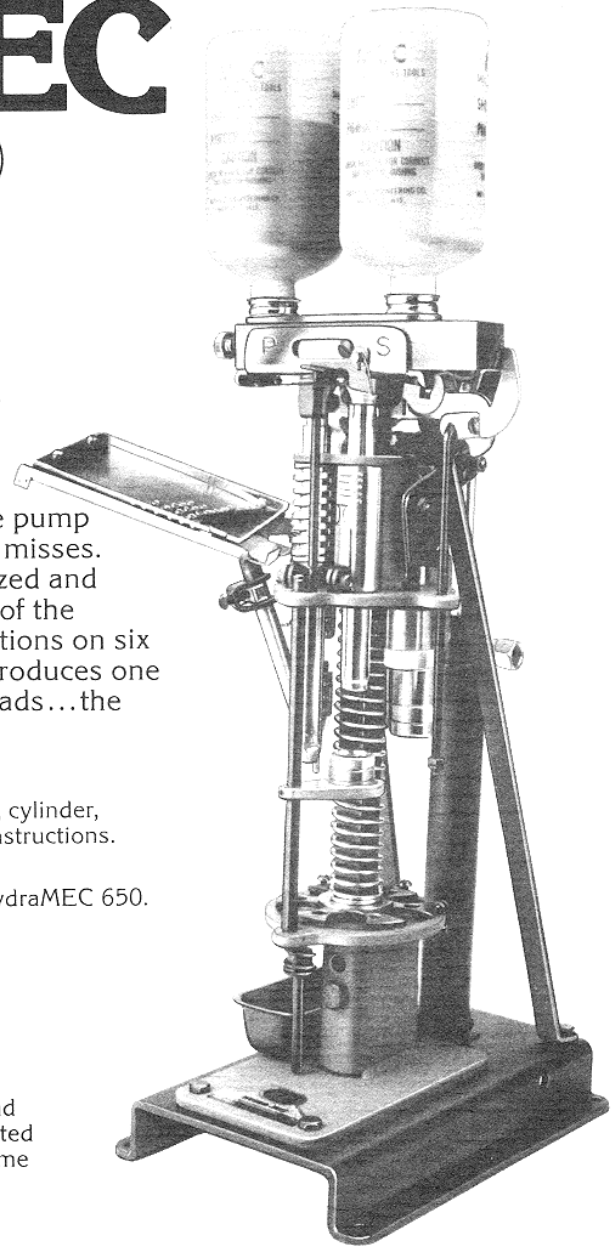

Mayville Engineering Company, Inc.
Mayville, Wisconsin 53050