



HIGH STANDARD SPORTING FIREARMS

THE LEISURE GROUP, INC. • 1817 DIXWELL AVENUE, HAMDEN, CONN. 06514 • TEL.: (203) 248-5531

MODEL TEN

SERIES "B"

12 GAUGE AUTOLOADING POLICE SHOTGUN

CATALOG #8291

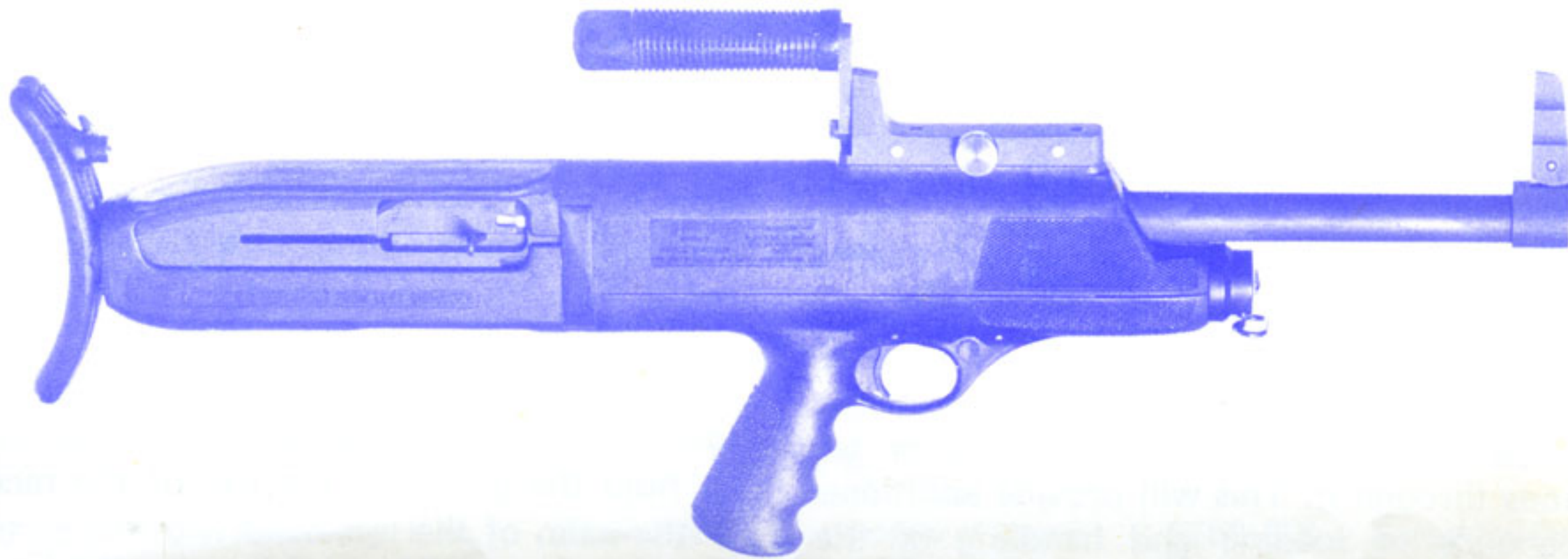

OPERATING INSTRUCTIONS AND PARTS LIST

HOW TO ORDER REPAIR PARTS

The following information must be furnished when ordering replacement parts:

1. Model Name and Number
2. Catalog Number and Series
3. Number and Name of Parts

SHOTGUN SHIPPING INSTRUCTIONS

CAUTION: For safety of all concerned — Be absolutely certain shotgun is empty . . . with no shells in chamber and magazine.

Shotgun should be securely packaged in a throwaway carton to prevent damage in transit. Do not ship shotgun to the factory in gun carrying case or other special containers which must be returned by our service department. Cartons are available from High Standard for \$1.50 each.

Shotgun should be shipped to the factory — Express Prepaid or insured parcel post.

REMEMBER: All Shipments to the factory must be Prepaid.

FACTORY SERVICE

If parts are to be fitted at the factory, send firearms marked for the attention of our SERVICE DEPARTMENT, furnishing complete and specific repair instructions. A cost estimate of the parts and labor charges will be immediately sent for your approval before work is started. Unless a flat rate charge is specified, a MINIMUM of \$8.50 will be charged on servicing firearms at the factory.

MINIMUM ORDER \$2.00

A minimum charge of \$2.00 is made on all orders where the normal cost would be less than \$2.00. If you wish, order extra parts to make up the minimum charge.

PAYMENT

All parts shipments will be made by Parcel Post C.O.D. unless advance remittance is made. PLEASE DO NOT SEND CASH OR STAMPS. Checks, Money Orders, or Drafts are acceptable and will save you C.O.D. charges.

OPERATING INSTRUCTIONS

The Model Ten Police Shotgun is gas operated, using a part of the gas pressure generated to operate the action of the firearm. This results in a reduction of the recoil of about 50% (compared to a pump-action shotgun). The Model Ten is designed to function either 2 $\frac{3}{4}$ " high base or 2 $\frac{3}{4}$ " magnum loads, interchangeably, without adjustment.

CLEANING EXTERIOR

For trouble free operation, clean the heavy protective oils from the exterior before firing. After cleaning, coat the exterior with light gun-oil. (Cleaning of the "action" is explained in a later part of the instructions).

Since the primary use for police shotguns is of an intermittent nature, it is suggested that a periodic check of the gun be made to insure that the action is functioning properly. The best method is to function five or ten rounds through it. This will provide additional experience in loading and handling of the Model Ten.

ILLUSTRATION #1

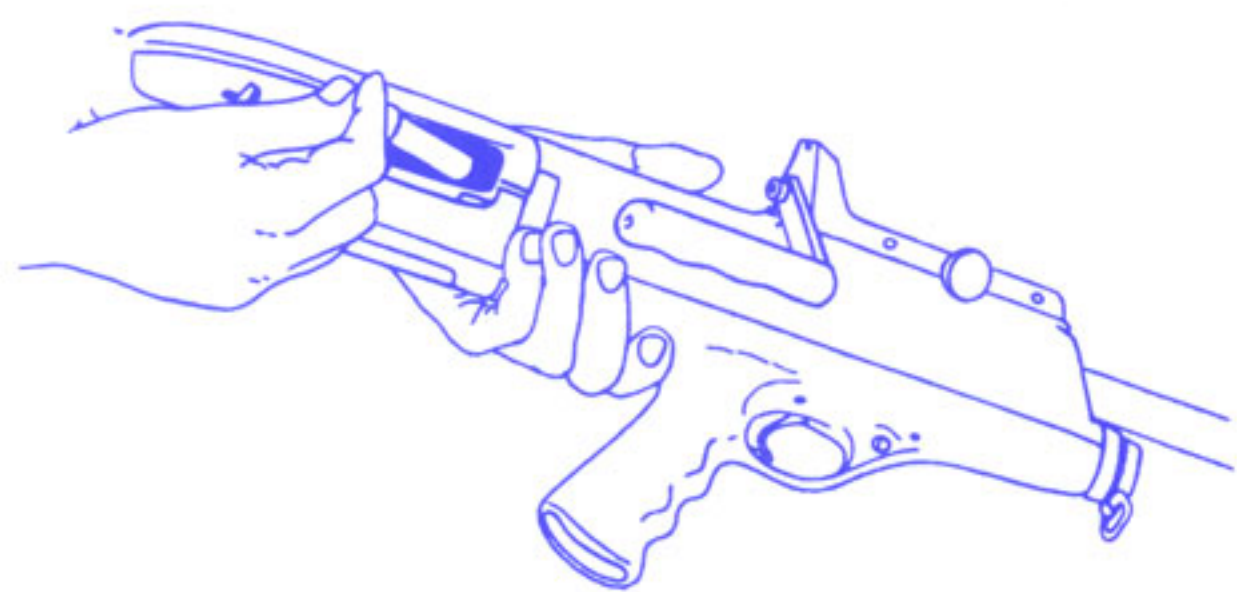

TO LOAD FIRST SHELL INTO CHAMBER —

Engage safety by pushing from left to right. Open the action by pulling either the R.H. or L.H. operating handles all the way to the rear. (Action will lock into "open" position). Drop shell into loading port. Push cartridge stop button and action will close, carrying shell into chamber.

ILLUSTRATION #2

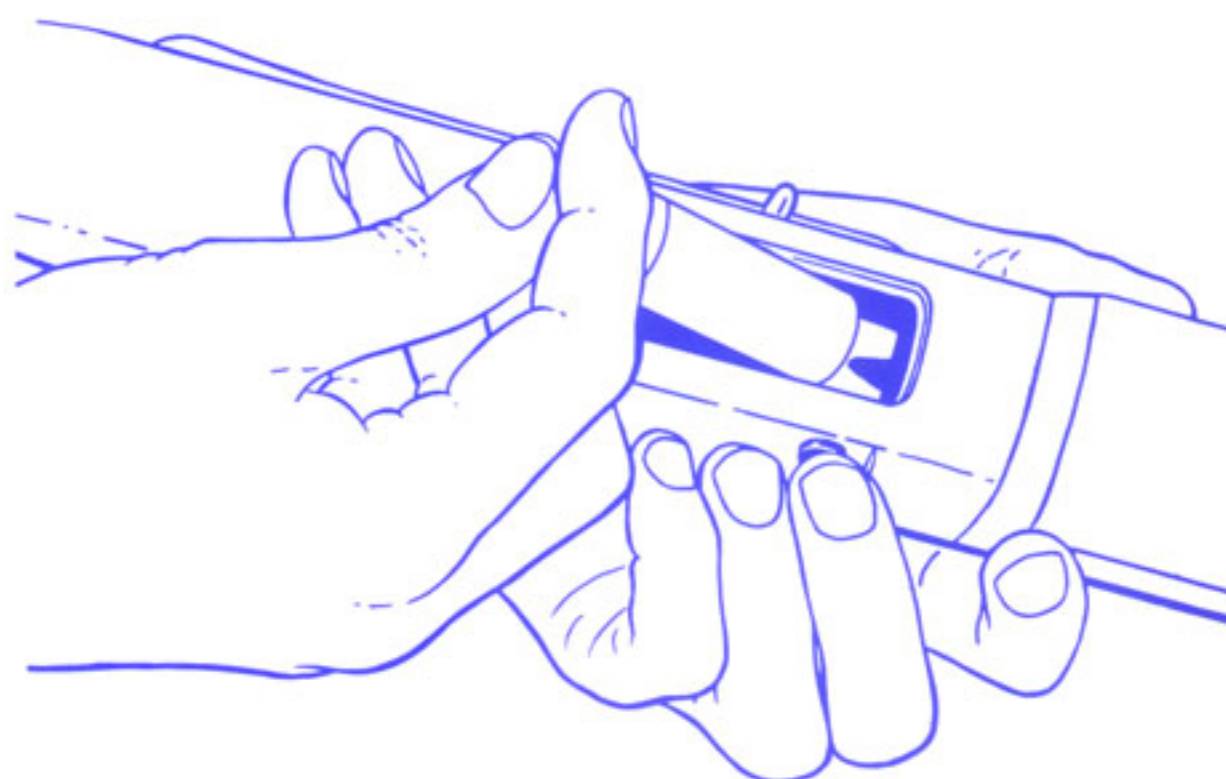

TO LOAD MAGAZINE — Depress cartridge stop button until cartridge lifter can be fully depressed. Insert shells into magazine tube, being sure to push each shell past the cartridge stops. Only slight pressure should be applied to the cartridge stop button when loading. The best method for doing this is to hold the gun with the top of the receiver in the palm of the left hand with the cartridge stop button depressed. Load four shells into the magazine tube by pushing downward and forward. Magazine holds four 2 $\frac{3}{4}$ " shells.

The gun is now fully loaded and ready to fire. To dis-engage the safety push from right to left (the red ring on the safety will now appear).

Note: When firing the gun be sure it is positioned so that the ejection port is facing outward to the right.

TO UNLOAD MAGAZINE — Push safety button from left to right, locking trigger. **Be sure Red Band on Safety is not visible.** Turn gun over — push cartridge stop button and depress cartridge lifter. Holding cartridge lifter down, press in cartridge stop on inside of receiver (the left side with gun upside down) to release shell from magazine. Repeat procedure until magazine is empty. **Be sure to Remove Loaded Shell from Chamber.**

TO REMOVE LOADED SHELL FROM CHAMBER — Be sure that safety button has been pushed from left to right and that red band on safety is not showing. Open action fully by pulling operating handle all the way back and loaded shell will be extracted.

EXPLODED VIEW OF MODEL TEN

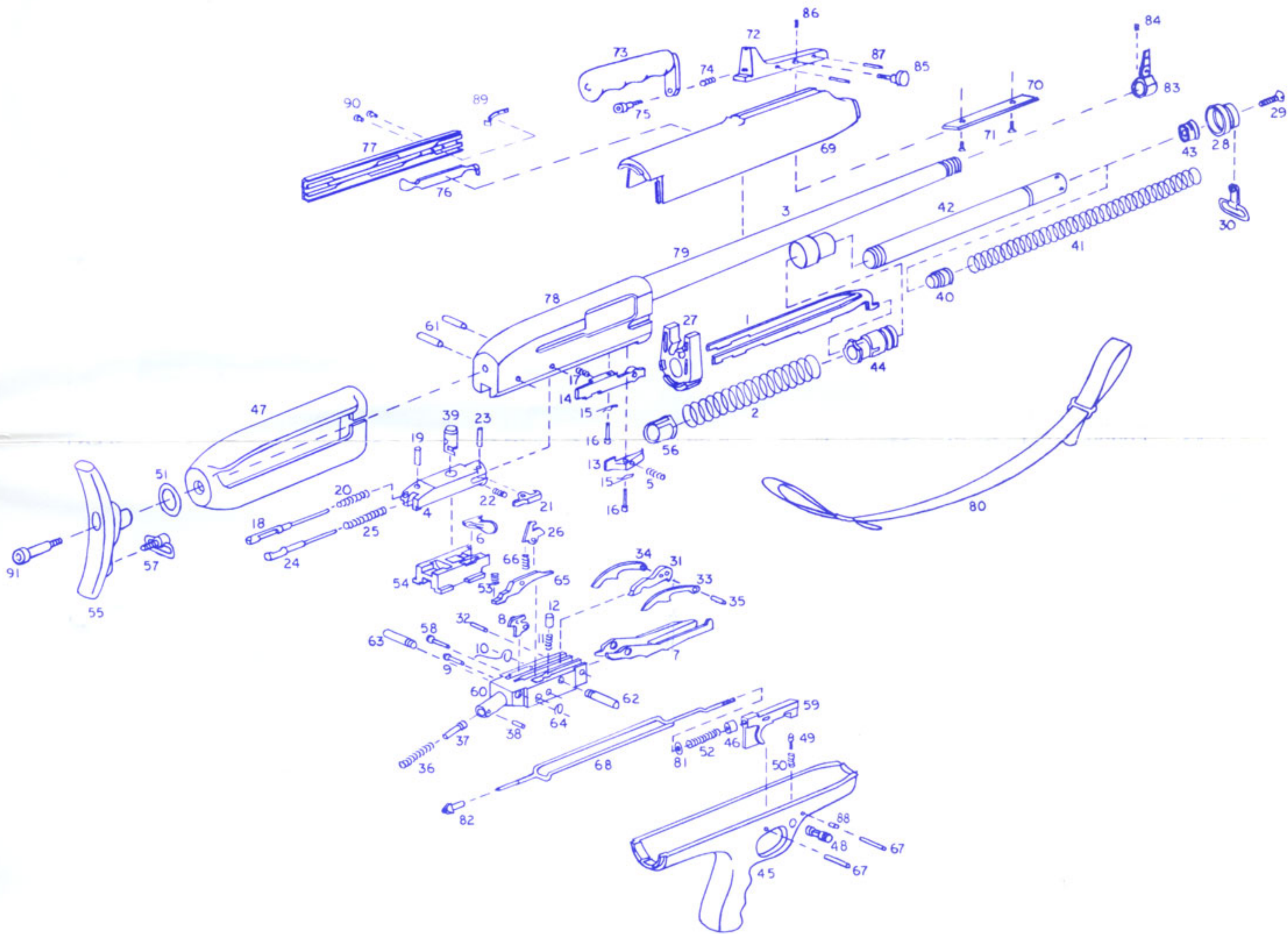

CAUTION: FOR SAFETY'S SAKE DO NOT ATTEMPT TO REPAIR SHOT GUN WITHOUT RECEIVING RELIABLE A

**PARTS LIST FOR MODEL TEN SERIES "B"
12 GAUGE AUTOLOADING POLICE SHOTGUN**

All parts identified with this mark (**) sold for factory installation only. Return complete shotgun to factory. Do not order repair parts by reference number, always use the part number.

(PRICES SUBJECT TO CHANGE WITHOUT NOTICE)

REF. NO.	PART NO.	DESCRIPTION	RETAIL PRICE EACH
1	**50173	Action Bar	\$10.50
2	3198	Action Spring	.95
56	3199	Action Spring Spacer	1.10
3	**50147	Barrel & Cyl. Assy.	35.00
79	**50143	Barrel & Rec. Assy.	Not sold
4	**50146	Bolt	15.25
N.I.	**50145	Bolt Assy.	27.50
73	50164	Carrying Handle Assy.	4.00
75	50169	Carrying Handle Ret. Screw	.95
74	50201	Carrying Handle Tension Spg.	.55
80	6826	Carrying Sling	2.75
7	**6868	Cartridge Lifter	5.50
8	**677	Cartridge Lifter Actuator Assy.	1.00
9	610	Cartridge Lifter Actuator Hinge Pin	.35
10	675	Cartridge Lifter Actuator Spg.	.35
11	50255	Cartridge Lifter Spring	.35
12	689	Cartridge Lifter Spring Plunger	.35
14	50208	Cartridge Stop Assy., L.H.	5.00
13	50203	Cartridge Stop, R.H.	2.75
16	50209	Cartridge Stop Pin	.35
15	50205	Cartridge Stop Pin Ret. Clip	.35
17	50194	Cartridge Stop Spring, L.H.	.35
5	50256	Cartridge Stop Spring, R.H.	.35
6	2409	Cocking Handle	1.70
18	739	Ejector	1.10
20	50257	Ejector Retracting Spring	.35
26	**873	Escapement Hook	1.10
66	50258	Escapement Hook Spring	.35
21	6865	Extractor, R.H.	2.50
23	119	Extractor Hinge Pin	.35
22	50259	Extractor Spring, R.H.	.35
24	626	Firing Pin	1.10
19	50206	Firing Pin & Ejector Ret. Pin	.35
25	50260	Firing Pin Retracting Spring	.35
87	50273	Flashlight Adapter Locating Pin (2)	.35
85	50269	Flashlight Ret. Screw	1.00
86	50271	Flashlight Ret. Screw Ret. Pin	.35
28	6821	Forehand Cap	1.70
29	50207	Forehand Cap Screw	.35
83	50188	Front Sight Assy.	2.00
84	1098	Front Sight Set Screw	.55
30	6825	Front Swivel Assy.	1.35
61	6843	Guard Ret. Pin (2)	.55
62	672	Guard Ret. Pin Bushing, Front	.55
63	673	Guard Ret. Pin Bushing, Rear	.55
31	**6818	Hammer	2.75
32	50196	Hammer Pivot Pin	\$.35

REF. NO.	PART NO.	DESCRIPTION	RETAIL PRICE EACH
36	50261	Hammer Spring	.35
37	639	Hammer Spring Guide	.35
38	676	Hammer Spring Ret. Pin	.35
33	641	Hammer Strut, R.H.	.40
34	642	Hammer Strut, L.H.	.40
35	643	Hammer Strut Pin	.35
27	**50174	Housing Coupling	6.75
39	691	Locking Pin	3.50
40	645	Magazine Follower	.55
41	50262	Magazine Spring	.55
42	50152	Magazine Tube	5.00
43	648	Magazine Tube Cap	1.05
76	50175	Operating Handle, L.H.	2.50
77	50176	Operating Handle Guide, L.H.	1.00
89	50275	Operating Handle Spring	.35
90	50276	Operating Handle Spring Rivet (2)	.35
45	50156	Pistol Grip Housing	14.50
44	50149	Piston Assy.	3.50
72	50170	Rear Sight Block	4.00
70	50171	Rear Sight Strap	.50
71	50172	Rear Sight Strap Screw (2)	.35
57	50182	Rear Swivel Assy.	1.40
78	**6811	Receiver	Not sold
47	50198	Receiver Housing	14.50
64	674	Retaining Spring Clip	.35
81	**6820	Rod Washer	.55
48	6808	Safety Button	1.10
50	50263	Safety Plunger Spring	.35
49	6848	Safety Spring Plunger	.55
65	**50154	Sear	4.50
58	699	Sear Pivot Pin	.55
53	50200	Sear Spring	.35
55	50279	Shoulder Yoke	4.00
91	6841	Shoulder Yoke Bolt	1.70
51	735	Shoulder Yoke Spring	.35
54	**50148	Slide	6.75
59	**6807	Trigger	2.75
60	**50181	Trigger Guard	11.00
N.I.	**50153	Trigger Guard Assy.	35.00
67	6842	Trigger Retaining Pin (2)	.55
52	**50199	Trigger Return Spring	.35
68	**50158	Trigger Rod Assy.	3.00
46	**50183	Trigger Rod Bushing	.35
82	**50197	Trigger Sear Nut	.75
88	50274	Trigger Stop Pin Bushing	.35
69	50163	Upper Housing	14.50
N.I.	50284	Carrying Case (Optional)	
N.I.	50285	Flashlight (Optional)	

N.I. Part not illustrated.

ICE. WE MAINTAIN A SERVICE DEPARTMENT WHICH WILL PROMPTLY GIVE YOU ADVICE AND SERVICE.

DIS-ASSEMBLY FOR CLEANING

ILLUSTRATION #3

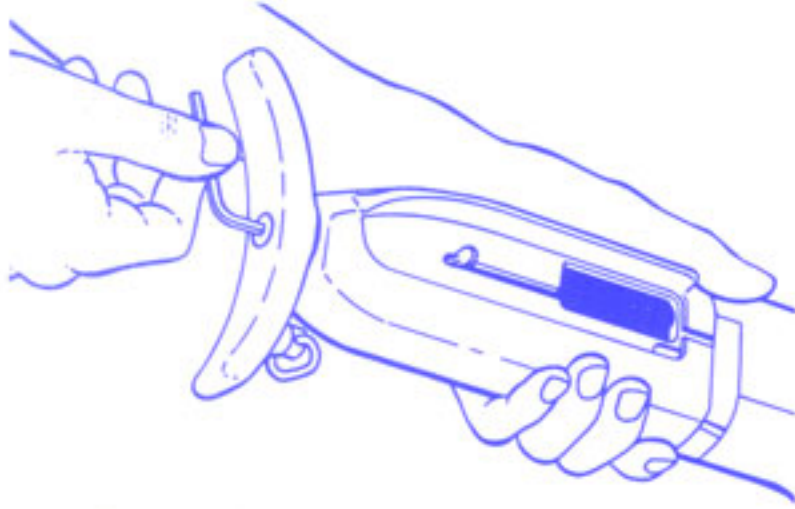

STEP ONE – Removing Shoulder Yoke. Open Action — Be sure gun is completely empty before starting disassembly. (See unloading information on page 2). Using a 3/16" hex key as shown in illustration #5, remove shoulder yoke, bolt and washer.

ILLUSTRATION #4

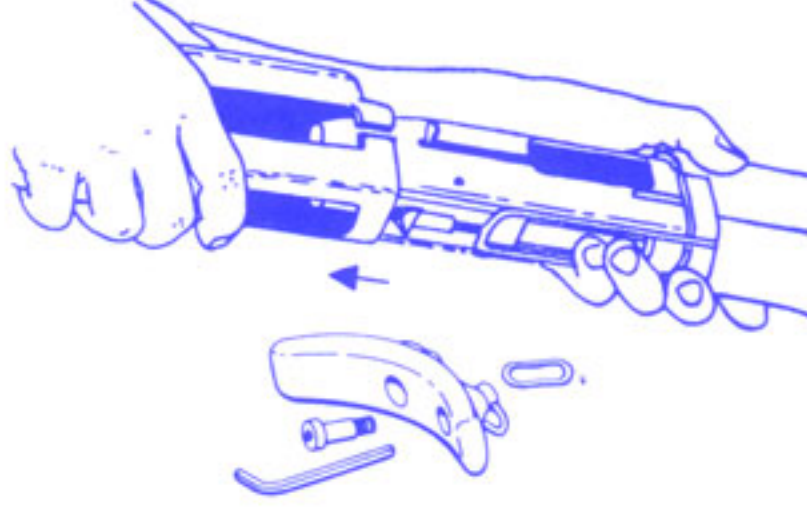

STEP TWO – Removing Receiver Housing. After removal of items in illustration #5, slide receiver housing rearward to remove.

ILLUSTRATION #5

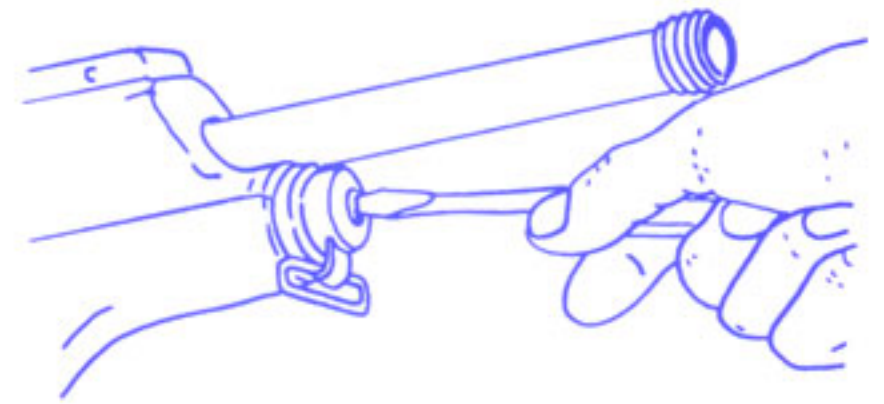

STEP THREE – Removing Front Sight Assembly and Magazine Cap. Using a standard hex key, loosen front sight retaining screw and remove sight. Front magazine cap is disassembled by removing cap screw as shown. Front cap and sling swivel are then removed together.

ILLUSTRATION #6



STEP FOUR – Removing L.H. Operating Handle and Guide. After removing front magazine cap, slide upper and lower housing forward approximately 2" away from housing coupling. Grasp L.H. operating handle guide and slide it rearward approximately 1" until it disengages locating lugs on upper and lower housings. Remove handle and guide by lifting away from housings.

Note: Re-assemble in reverse order.

ILLUSTRATION #7

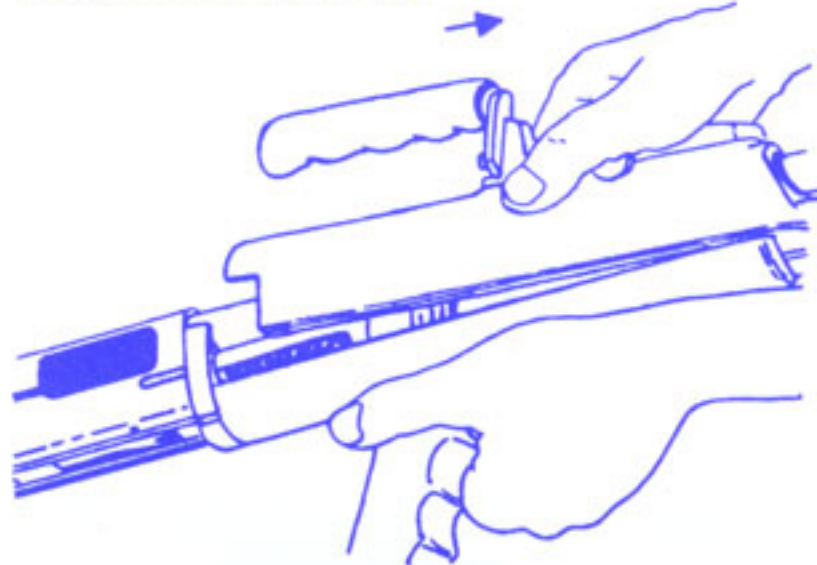

STEP FIVE – Disassembly of Upper Housing Assembly. After removal of L.H. operating handle guide, upper housing assembly can be removed by sliding forward.

ILLUSTRATION #8

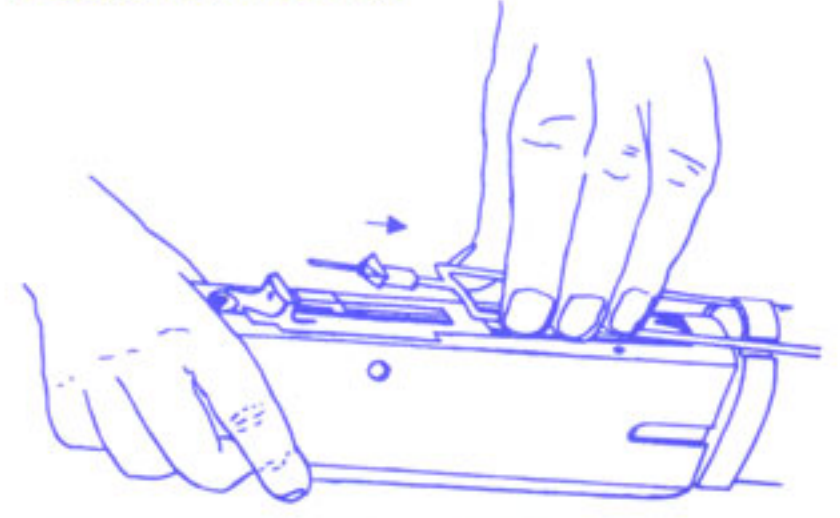

STEP SIX – Removing Pistol Grip Housing. Slide pistol grip housing forward until trigger rod is clear of hole in trigger guard. Trigger rod can now be removed by springing rod out of both slots in housing coupling.

Note: Re-assemble in reverse order.

ILLUSTRATION #9

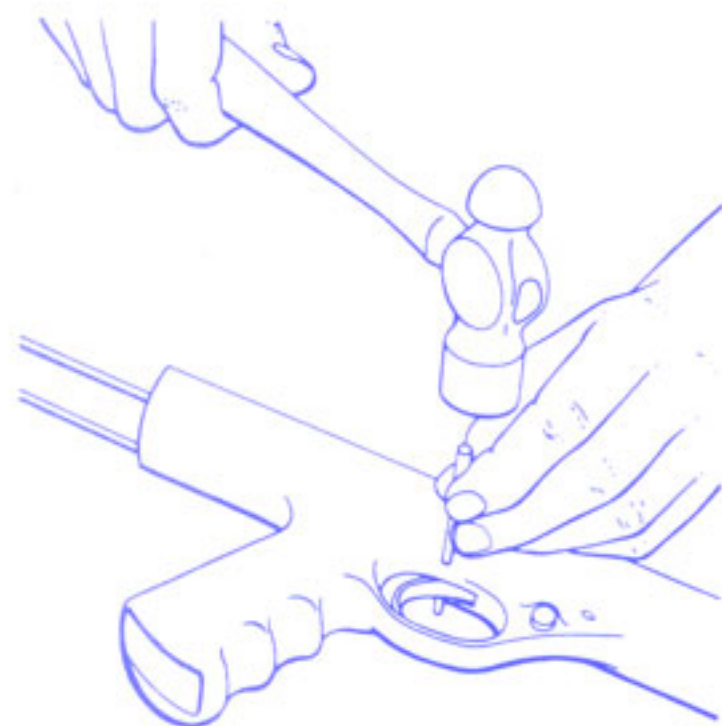

STEP SEVEN – Removing Trigger Retaining Pin. To remove trigger retaining pin, drive out with punch as shown in illustration #9.

Note: Drive pin from right to left. Re-assemble in reverse order.

ILLUSTRATION #10



STEP EIGHT – Dis-assembly of Pistol Grip Housing. To remove trigger spring, rod and assembly, dis-engage safety by pushing from right to left, then grasp trigger and draw rearward and out.

Note: Assemble in reverse order.

CLEANING THE ACTION

The Model Ten has been designed to practically eliminate lubrication of all operating parts. However, it is important to keep the following parts of the action clean and free from residue build-up. After removing the upper housing assembly and pistol grip unit, the operating piston, spring and magazine tube will be exposed. Do not remove magazine tube or piston from gun. Retract piston manually and clean tube and piston parts thoroughly with a solvent to remove all residue. Dry the action with an air hose or wipe clean with a lint-free cloth.

Do not oil these parts.

OTHER LAW ENFORCEMENT FIREARMS

from **HIGH STANDARD**

DERRINGER — *The Ideal "Second Gun"*

1. **FLAT and THIN** for easy concealment. Light weight — 11 oz. — for law enforcement hide-out gun.
2. **BUILT IN SAFETY** hammer block. Won't fire if dropped.
3. **DOUBLE ACTION** — smoothest, safest, fastest handling Derringer made.
4. **TWO SHOTS.** (Single shot Derringers give only one chance at your target).
5. **PALM FILLING GRIP** designed for shooting control.
 - (a) Models 9193 and 9305 shoot .22 Long Rifle (use of hollow-point cartridges recommended).
 - (b) Models 9194 and 9306 shoot .22 Rim Fire Magnum caliber, high velocity, hollow-points and full metal case bullets — A Tremendous Wallop!
6. **HAMMERLESS** — no snag on pocket. (Hammer types are almost impossible to cock for second shot).
7. **RECESSED HEAD SPACE** for extra safety.
8. **DUAL EXTRACTION!** Easy to load and operate.
9. **ALL STEEL** unit is encased in rich blue, anodized, or nickel plated, light weight alloy housing.
10. **DURABLE** and accurate barrels — all steel.

.22 Caliber L.R.
Stock #9193—Blue
Stock #9305—Nickel



.22 Caliber Magnum
Stock #9194—Blue
Stock #9306—Nickel

RIOT GUNS — *Accurate, Hard Hitting*

designed exclusively for police use by High Standard

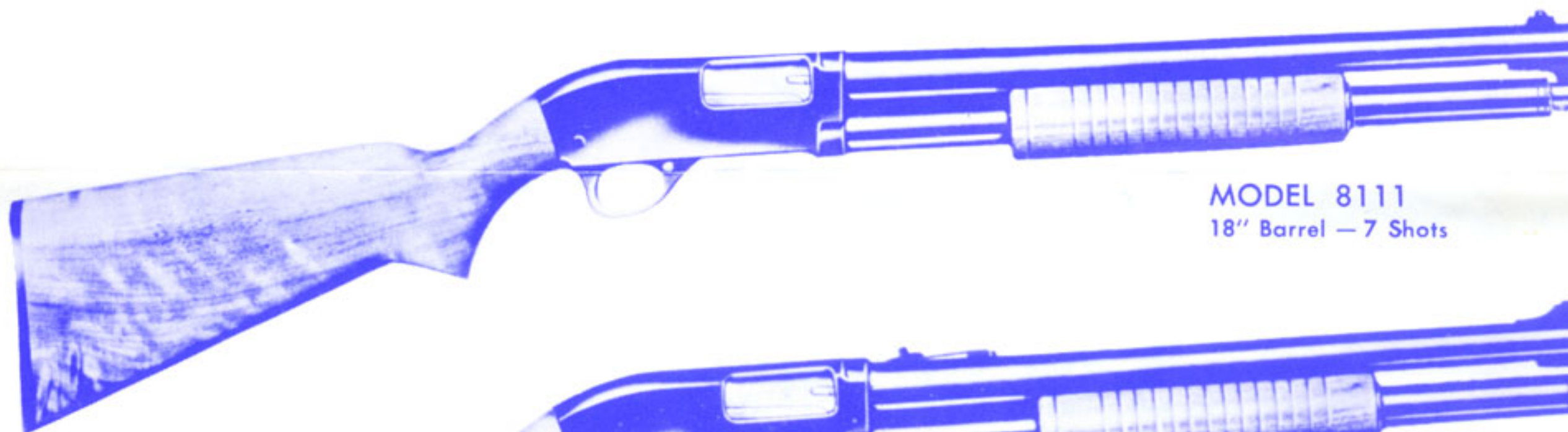

MODEL 8111
18" Barrel — 7 Shots

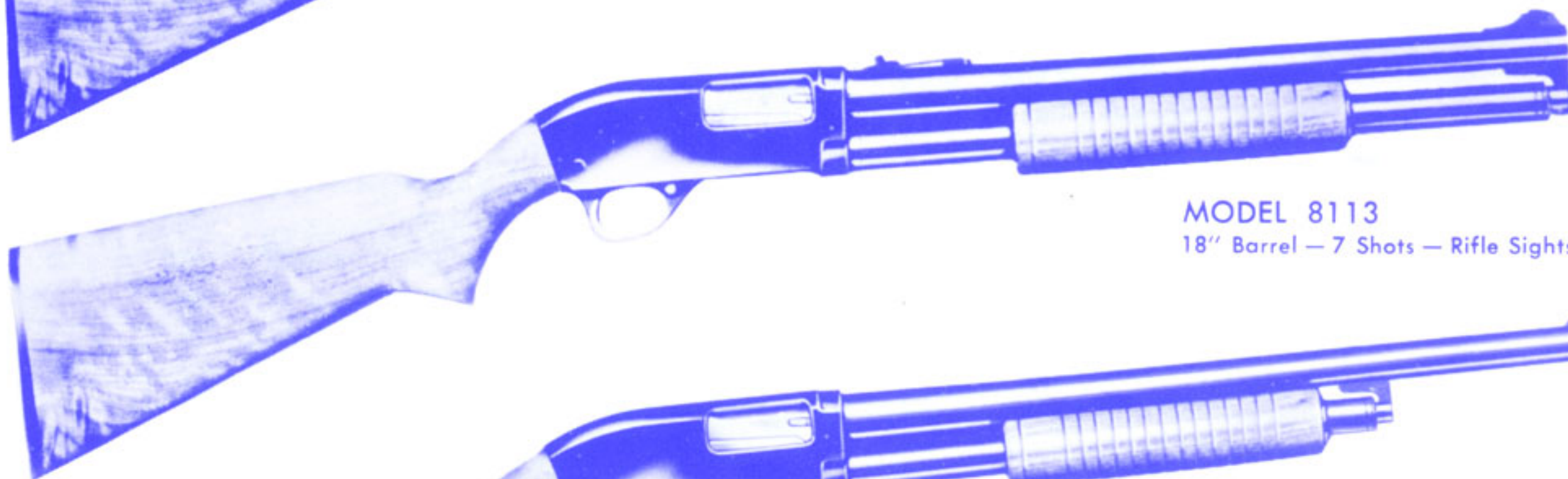

MODEL 8113
18" Barrel — 7 Shots — Rifle Sights

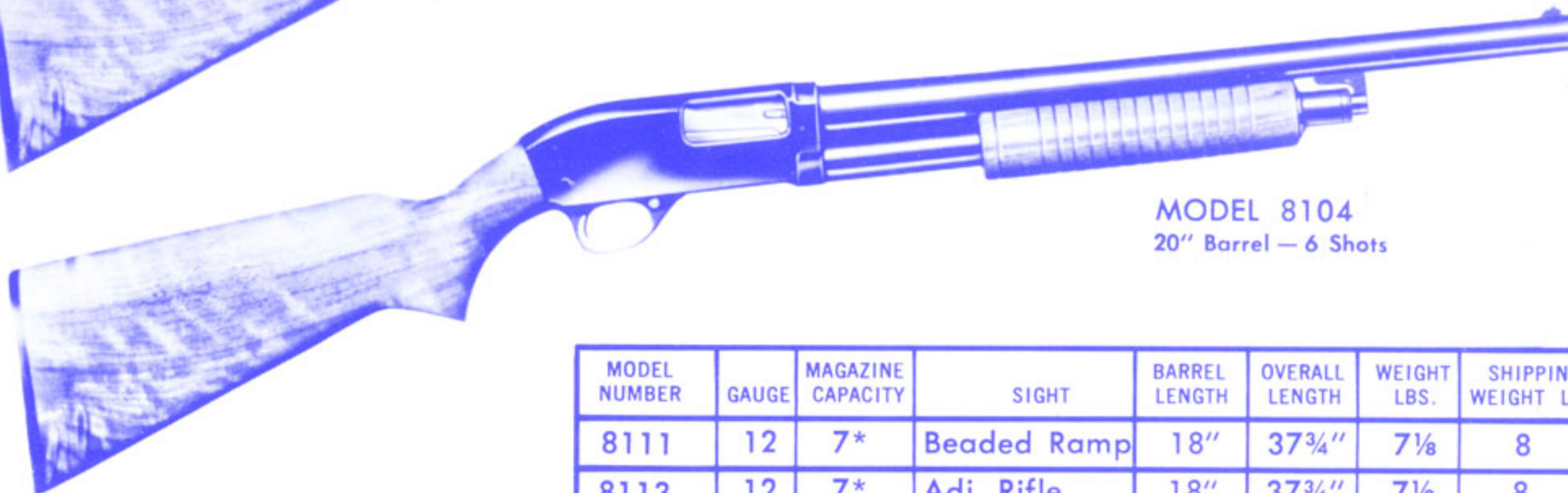

MODEL 8104
20" Barrel — 6 Shots

MODEL NUMBER	GAUGE	MAGAZINE CAPACITY	SIGHT	BARREL LENGTH	OVERALL LENGTH	WEIGHT LBS.	SHIPPING WEIGHT LBS.
8111	12	7*	Beaded Ramp	18"	37 ³ / ₄ "	7 ¹ / ₈	8
8113	12	7*	Adj. Rifle	18"	37 ³ / ₄ "	7 ¹ / ₈	8
8104	12	6**	Beaded Ramp	20"	39 ³ / ₄ "	7	8 ¹ / ₂

SPECIAL FEATURE

All Riot Gun stocks and forearms are oiled American walnut. Stocks are drilled for quick attachment of sling swivels. Sling and swivels are available as extra option.

*7 shots with six shells in magazine and 1 in the chamber.

**6 shots with five shells in magazine and 1 in the chamber.



HIGH STANDARD

SPORTING FIREARMS