

GENERAL INSTRUCTIONS

Nemesis air pistols are supplied in specially designed packaging and are ready for immediate use once familiarisation of the air pistol and an appreciation of the basic safety rules have been completed.

The Basic Safety Rules:

1. Treat every pistol as if it is loaded.
2. Never point a pistol at ANYONE, or allow anyone to point a pistol at you even if you think it is not loaded.
3. Always carry the pistol so that the direction of the muzzle is under control, even if you stumble.

OPERATING INSTRUCTIONS

Note: The Nemesis is designed primarily to shoot lead waisted pellets only, however as with other similar pistols, the use of some of the commercially available heavyweight or oversize pellets may compromise its performance. Use only Webley recommended pellets to ensure optimum performance.

To Load

The Nemesis is fitted with a manual safe which may be applied before or after the pistol is cocked. The safe is disengaged only when the red dot on the left hand top side of the safe is visible. i.e. a loaded pistol will discharge if the trigger is pulled.

Using the thumb of the hand holding the pistol grip, pull down the barrel catch, N21 and fully open the barrel assembly with the free hand. (fig.1)

With the barrel in the fully open position, insert a pellet into the barrel chamber (fig.2 and fig.3).

Then, avoiding contact with the rearsight close the barrel with the free hand until it engages with the catch, (fig.4) – the closing force will increase as the air is compressed in the cylinder assembly. Keep fingers away from the trigger whilst cocking to prevent unintentional discharge.



Do not open the barrel catch of a charged pistol or allow the barrel assembly to spring back uncontrolled against the compressed air pressure during the cocking sequence as damage may result.

If desired, apply the safe, N60 by pushing its left hand side as far as it will go, the red dot will then disappear.

When ready to fire, point the pistol towards the target and take a comfortable stance. If applied, disengage the safe and squeeze the trigger until the pistol discharges.

4. Always be sure of your target and what lies behind it before you squeeze the trigger.
5. Never leave a loaded pistol unattended.
6. Beware of targets which tend to cause ricochets.

The Law

KNOW THE LAW ON AIRGUNS AND OBEY IT.

ACT RESPONSIBLY, ACT SAFELY, THEN ENJOY YOUR SHOOTING.

Trigger Pull Adjustment

The 2-stage trigger mechanism is factory set to give a light pull first stage pretravel, then a short travel, heavier second stage pull.

If a shorter first stage and longer second stage travel is required, turn the trigger adjusting screw, N53 clockwise using a suitable screwdriver. Conversely if a longer first stage right up to the release point is required, turn the screw anticlockwise. Make slight adjustments only before rechecking the trigger pull, as the setting is sensitive.

IMPORTANT

The safe setting screw, N54 positions the trigger relative to the safe and sear. **DO NOT** touch this grub screw when adjusting the trigger pull.

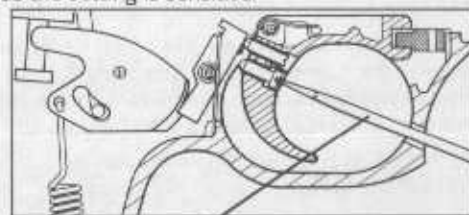

The illustration (fig.5) shows how to adjust the Trigger Pull

Fig.5

Adjusting The Rearsight (Zeroing)

Always take the same point of aim during adjustment, regardless of the resultant point of impact. Shoot at least five pellets between adjustments, using the average of the group for reference.

Vertical Adjustment

To correct a pistol shooting high, turn the rearsight elevation screw, N80 clockwise to lower the rearsight leaf, N78. To correct a pistol shooting low, turn the rearsight elevation screw anti-clockwise to raise the rearsight leaf.

Windage Adjustment

To correct a pistol shooting to the right, turn the rearsight horizontal screw, N86 anti-clockwise to move the rearsight blade, N85 to the left. To correct a pistol shooting to the left, turn the rearsight horizontal screw clockwise to move the rearsight blade to the right.

Fitting An Optional Pistolscope

A dovetail is provided on the barrel housing to allow a pistolscope or other sighting systems to be fitted (fig.6).

Position the pistolscope on the barrel housing as far as is possible to leave the maximum possible amount of space free for the hand to load the pistol.



Fig.6

Note: THE BARREL HOUSING IS MADE FROM A POLYMER COMPOSITE MATERIAL. DAMAGE MAY OCCUR IF A MOUNT INCORPORATING SOCKET HEAD CLAMP SCREWS OR SIMILAR ARE EXCESSIVELY TIGHTENED ONTO THE HOUSING.

The absence of recoil on the Nemesis eliminates the need to clamp the pistolscope as firmly to the housing as would be necessary on a recoiling air pistol.

Routine Care

1. Do not leave the pistol loaded or cocked when not in use. Leaving it cocked for prolonged periods may affect the life of the valve and piston seals.
2. After use, wipe the metal parts such as screws, barrel (including barrel bore) with oil to prevent corrosion. Use Weboil lubricant.
3. Very occasionally apply three or four drops of Weboil lubricant to:-
 - a) Barrel and cylinder pivots, N23.
 - b) Piston rod pivot, N32.
 - c) Rod of piston assembly, N36.
 - d) Air cylinder bore, access is gained through the air feed hold drilled towards the rear of the air cylinder, N26. Apply oil with the barrel assembly fully open.
 - e) Trigger pivot, N57. Access is gained through the slot in the trigger guard.
 - f) Sear pivot, N43. Access is gained through the slot in the rear of the trigger guard.
 - g) Rotary striker pivot, N42. (During major overhaul only as stocksides must be removed for access.)

DISMANTLING INSTRUCTIONS

SHOULD THE PISTOL DEVELOP A FAULT WITHIN THE GUARANTEE PERIOD CONSULT THE DEALER FROM WHOM IT WAS PURCHASED. THE GUARANTEE DOES NOT COVER PARTS INADVERTANTLY DAMAGED, NOR PISTOLS INCORRECTLY ASSEMBLED, BY THE OWNER.

ENSURE THE PISTOL IS NOT LOADED BEFORE PROCEEDING WITH ANY DISMANTLING.

If a loaded pistol has failed to discharge the pellet when the trigger is pulled, adopt the following procedure:

- a) APPLY THE SAFE AND TAKE ALL POSSIBLE SAFETY PRECAUTIONS TO ENSURE INJURY OR DAMAGE WILL NOT RESULT SHOULD THE PISTOL DISCHARGE SUDDENLY.
- b) Pull down the barrel catch and open the barrel assembly, preventing it from springing back uncontrolled due to any remaining compressed air pressure.
- c) Remove the pellet from the barrel.
- d) Check the condition of the breach seal, N18 and replace if necessary.
- e) Remove the stocksides as described under 'Major Overhaul or Repair', ensuring the rotary striker spring, N41 is connected to the rotary striker spring anchor pin, N42 and the rotary striker assembly, N40.
- f) Close the barrel assembly and listen for leaks. If air is heard to be leaking check the condition of all seals and replace worn components where necessary – refer to the relevant sections in this manual when fitting new seals.
- g) If no air leaks are apparent, pull the trigger to release the compressed air. With the pistol fired, the head of the valve spindle, N15 should be resting in its frame stop. If there is a gap, the air valve assembly is not opening fully. To fully discharge a pistol with this fault, use a screwdriver to lever the air valve spindle head against the frame stop as shown in fig.7.



Fig.7

This fault is likely to be due to a weakened rotary striker spring, therefore replace and ensure the air valve opens fully before resuming normal shooting.

- h) If the valve spindle head is sitting on its frame stop, check the valve spindle is screwed tightly against the air valve, N9. Refer to the 'Air Valve Assembly' section in this manual for further information.

- i) Check the barrel is clamped tight in the barrel housing, N63 and is resting against the breech seal. Refer to 'The Barrel Assembly' section in this manual should it be necessary to adjust the location of the barrel.

Major Overhaul or Repair (for a Qualified Repairer).

The recommended overhaul procedure is as follows using Weboil lubricant as and where necessary:

1. Stocksides

Unscrew and remove the two stock screws, N4 from the right hand stockside, N2. Both stocksides can be removed from the frame – the left hand stockside, N3 complete with its screws and stockside nuts, N5. Removal of the right hand stockside may withdraw the spring anchor pin from the frame, thus disconnecting the rotary striker spring.

2. Removal of the Barrel and Cylinder Assemblies from the Frame

The rotary striker assembly, N40 is linked to the cylinder assembly by the rotary striker lifter, N44 and can only be removed from the frame as a unit.

Remove the stocksides as prescribed.

Unhook the rotary striker spring, N41 from the spring anchor pin, N42 if these components were not disconnected when the stocksides were removed.

Unhook the rotary striker spring from the rotary striker assembly and place to one side.

Push out the rotary striker pivot, N42 using a suitable drift. Open the barrel assembly and remove one of the barrel pivot circlips and one of the cylinder pivot circlips, N24. Tap out both pivots, N23 using a suitable drift. The barrel assembly, cylinder assembly, rotary striker assembly and rotary striker lifter can now be withdrawn from the frame as a unit. Take care not to lose the barrel pivot shims, N64 sandwiched between the frame and barrel housing.

Unhook the rotary striker lifter from the valve box, N8 and rotary striker assembly.

Reassemble in the reverse order, lightly lubricating all parts. Take care to refit the barrel pivot shims and ensure the rotary striker spring is fitted the correct way, i.e. the eye of the spring is fitted over the spring anchor pin and the spring hook is fitted into the righthand side rotary striker assembly hole. Hook end facing upwards.

- Rear sight adjustable for both windage and elevation.
- Manual safe for selective use.
- Ambidextrous grip design suitable for both left and right hand shooters.
- Dovetail allows owner to fit optional sight systems.
- Overall length 9.84 inches (25cm).
- Barrel length 7.72 inches (19.6cm).
- Weight 2.2lbs (1.0kg).

The Webley NEMESIS Pneumatic Air Pistol

- Single stroke pneumatic, single shot capacity.
- Precision Rifled Barrel available in .177" (4.5mm) and .22" (5.5mm) calibres.
- Adjustable two-stage trigger mechanism.

DISMANTLING INSTRUCTIONS (cont)

THE FOLLOWING INSTRUCTIONS ASSUME THE BARREL ASSEMBLY, CYLINDER ASSEMBLY, ROTARY STRIKER ASSEMBLY AND ROTARY STRIKER LIFTER HAVE BEEN DISMANTLED FROM THE FRAME.

3. The Barrel Assembly

Loosen the piston rod pivot fixing screw, N33 using a 1/4" A/F socket key, N95 then push out the piston rod pivot, N32 using a suitable drift.

The barrel assembly can then be separated from the cylinder assembly.

To remove the barrel, N69 - .177 cal. N70 - .22 cal, undo the barrel fixing screw, N72 in the front of the barrel housing, N63 using a 2mm A/F socket key, N96 then unscrew and remove the barrel clamp screws, N74 and barrel clamp, N73. The barrel clamp nuts, N75 will then fall out of the top of the barrel housing.

Push the barrel rearwards into the barrel housing and remove. Slide the cushioning bush, N71 off the barrel.

To remove the barrel housing catch bar, N65 first remove its circlips, N66 located inside the barrel housing then push out the bar.

Reassemble in the reverse order but leave the barrel a loose fit in the barrel housing until the pistol is rebuilt. Ensure the barrel housing catch bar is fitted with its chamfer positioned as illustrated (fig.8).

Note the barrel has been indented by the point of the barrel fixing screw and this indent should be roughly positioned in line with the screw.



With the pistol rebuilt and the barrel assembly closed, push the barrel against the breach seal, N18 housed in the valve box, N8 allowing the point of the barrel fixing screw to relocate into the barrel indent. Tighten the barrel fixing screw then open the barrel assembly and tighten the barrel clamp screws.

The above procedure should also be adopted when fitting a new barrel which has not been indented by the fixing screw.

4. Rearsight Assembly

The rearsight pivot, N79 is retained in the barrel housing by a circlip, N88 which is located in a slot in the barrel housing. Using a suitable drift, tap out the rearsight pivot taking care not to lose the circlip. It is advisable to replace the circlip every time the rearsight is removed from the barrel assembly. Unscrew the rearsight vertical screw, N80 - the rearsight vertical screw nut, N81 will then drop from its slot in the barrel housing. Separate the rearsight assembly from the barrel housing, taking care not to lose the 2 rearsight elevating springs, N82. To remove the rearsight blade, N85 from the rearsight leaf, N78 remove the rearsight horizontal screw circlip, N88 and unscrew the horizontal screw, N86 until it can be withdrawn from the rearsight leaf together with the tensioning washer, N87.

Reassemble in reverse order.

5. The Cylinder Assembly

Remove the cylinder assembly from the barrel assembly as prescribed under the 'Barrel Assembly' section.

Take care to avoid damaging the thin-wall cylinder tube when proceeding with the following instructions.

To remove the piston assembly, N36 it is advisable to use a suitable 'C' spanner to release the piston rod bush, N31 from the air cylinder, N26. Once released unscrew the piston rod bush and carefully withdraw the piston rod assembly from the cylinder.

Alternatively, the air cylinder may be unscrewed from the valve box assembly and the

piston rod assembly can be withdrawn without removing the piston rod bush. Take care not to damage or lose the valve box spigot seal, N19 if this dismantling method is undertaken. Inspect the piston seal, N28, piston slide ring, N29, piston rod slide ring, N34 which is housed in the piston rod bush, and the valve box spigot seal if the cylinder has been separated from the valve box assembly. Replace worn or damaged parts.

NOTE THE PISTON HEAD IS FACTORY FITTED TO THE PISTON ROD AND MUST NOT BE SEPARATED.

Check the condition of the breach seal, N18 housed in the valve box, N8 and replace if necessary. To remove the barrel catch, N21 tap the valve box pivot bush, N20 out of the valve box using a suitable drift. The barrel catch can then be withdrawn, together with the barrel catch spring, N22.

6. Air Valve Assembly

Using a 13mm A/F spanner unscrew the valve bush, N14 from the valve box, N8 and withdraw the valve assembly, N16. Inspect all parts for wear and damage and renew if necessary.

The air valve spindle, N15 is bonded to the air valve, N9 and this bond should not be broken. Therefore, should any of the air valve assembly components require replacement, a complete new assembly must be fitted. The only exception to this is the air valve seal, N10 which may be replaced whenever necessary.

Lightly lubricate the valve assembly before refitting to the valve box, ensuring all components are scrupulously clean as dirt around this area may compromise the efficiency of the valve and affect the performance of the pistol.

7. Trigger Mechanism

To remove the safe, N60 push its leg away from the frame detent face into the recess using a screwdriver and push the safe out of the left hand side of the frame.

To remove the trigger, N52 push the trigger pivot, N57 out of the frame using a suitable diameter drift - it may be unnecessary to push the coil of the trigger spring, N56 out of the undercut machined in the trigger pivot to achieve removal. With the trigger pivot removed, the trigger and trigger spring can be withdrawn from the frame.

To remove the sear, N47, push out the sear pivot, N43 with the same drift used to remove the trigger pivot pin, then withdraw the sear and sear spring, N48, from the frame.

Refit in the reverse order, lightly lubricating all parts. Ensure the springs are correctly positioned on the trigger and sear before refitting to the frame - refer to diagram in the 'Trigger Pull Adjustment' section.

When refitting the safe, pull the trigger as far as it will go, then push the safe through the left hand aperture of the frame - its leg will automatically spring against the frame detent face.

SETTING THE TRIGGER TO THE SAFE AND SEAR

The safe setting screw, N54 housed in the trigger blade is factory set to position the trigger relative to the safe and sear.

Should it become necessary to re-adjust the safe setting screw, indicated by difficulty in engaging the safe, adopt the following procedure:

Remove the stocksides as prescribed, then cock the pistol. Push the trigger forwards until it is felt to contact the underneath of the safe, then apply the safe and using a suitable screwdriver adjust the safe setting screw until the 'bent' of the sear begins to rotate out of full engagement with the rotary striker.

Adjusted correctly, the trigger will just contact the underneath of the safe when the safe setting screw contacts the sear without reducing its bent engagement with the rotary striker.

Once adjusted, refit the stocksides, disengage the safe and discharge the cocked pistol. If the second stage trigger pull requires resetting, refer to the 'Trigger pull adjustment' section.

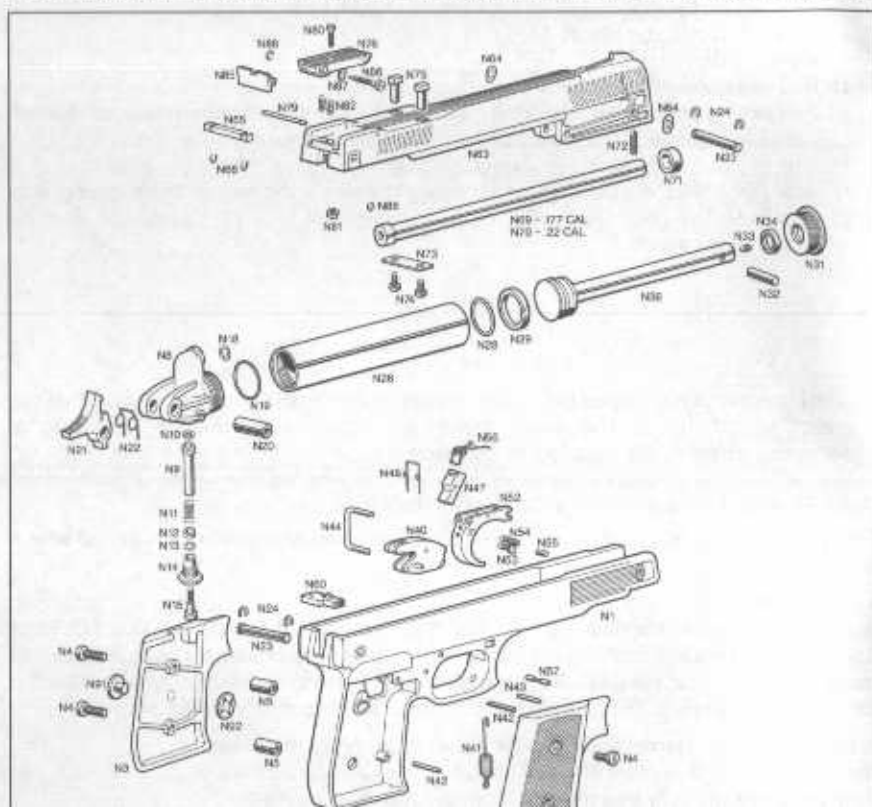

SPARE PARTS LIST FOR THE NEMESIS AIR PISTOL

| Part No. | Description | No. Off | Part No. | Description | No. Off |
|------------------------------|---------------------------------------|---------|---|---|---------|
| N1 | Frame | 1 | N48 | Sear Spring | 1 |
| N2 | Stockside Right Hand | 1 | N52 | Trigger | 1 |
| N3 | Stockside Left Hand | 1 | N53 | Trigger Adjusting Screw | 1 |
| N4 | Stockside Screw | 4 | N54 | Safe Setting Screw | 1 |
| N5 | Stockside Nut | 2 | N55 | Trigger Screw Tensioner | 1 |
| N6 | Valve Box | 1 | N56 | Trigger Spring | 1 |
| N9 | Air Valve* | 1 | N57 | Trigger Pivot | 1 |
| N10 | Air Valve Seal* | 1 | N58 | Trigger Assembly - not illustrated | 1 |
| N11 | Air Valve Spring* | 1 | (comprises N52, N53, N54, N55) | | |
| N12 | Air Valve Sleeve* | 1 | N60 | Safe | 1 |
| N13 | Air Valve Stem Seal* | 1 | N63 | Barrel Housing | 1 |
| N14 | Valve Bush* | 1 | N64 | Barrel Pivot Shim | 2 |
| N15 | Valve Spindle* | 1 | N65 | Barrel Housing Catch Bar | 1 |
| N16 | Air Valve Assembly* - not illustrated | 1 | N66 | Barrel Housing Catch Bar Circlip | 2 |
| (comprises N9-N15 inclusive) | | | N69 | .177 Barrel | 1 |
| N18 | Breach Seal | 1 | N70 | .22 Barrel | 1 |
| N19 | Valve Box Spigot Seal | 1 | N71 | Barrel Cushioning Bush | 1 |
| N20 | Valve Box Pivot Bush | 1 | N72 | Barrel Fixing Screw | 1 |
| N21 | Barrel Catch | 1 | N73 | Barrel Clamp | 1 |
| N22 | Barrel Catch Spring | 1 | N74 | Barrel Clamp Screw | 2 |
| N23 | Barrel & Cylinder Pivot | 2 | N75 | Barrel Clamp Nut | 2 |
| N24 | Barrel & Cylinder Pivot Circlip | 4 | N78 | Rearsight Leaf | 1 |
| N25 | Air Cylinder | 1 | N79 | Rearsight Pivot | 1 |
| N28 | Piston Seal | 1 | N80 | Rearsight Vertical Screw | 1 |
| N29 | Piston Slide Ring | 1 | N81 | Rearsight Vertical Screw Nut | 1 |
| N31 | Piston Rod Bush | 1 | N82 | Rearsight Elevating Springs | 2 |
| N32 | Piston Rod Pivot | 1 | N85 | Rearsight Blade | 1 |
| N33 | Piston Rod Pivot Fixing Screw | 1 | N86 | Rearsight Horizontal Screw | 1 |
| N34 | Piston Rod Slide Ring | 1 | N87 | Rearsight Horizontal Screw Washer | 1 |
| N36 | Piston Assembly | 1 | N88 | Rearsight Pivot & Horizontal Screw Circlip | 2 |
| N40 | Rotary Striker Assembly | 1 | N89 | Rearsight Assembly - not illustrated | 1 |
| N41 | Rotary Striker Spring | 1 | (comprises N78, N85, N86, N87, N88 1 off) | | |
| N42 | Striker Pivot & Spring Anchor Pin | 2 | N91 | Logo Badge | 1 |
| N43 | Sear Pivot | 1 | N92 | Logo Badge Clip | 1 |
| N44 | Rotary Striker Circlip | 1 | N98 | Logo Badge Mount - not illustrated (Optional) | 1 |

**This owner's manual was
provided as a service to you
by:**



www.airgunsofarizona.com

airguns_az@yahoo.com

Phone: (480)461-1113

Fax: (480)461-3928